



# SPRAY NOZZLES FOR INDUSTRIAL APPLICATIONS



**INDUSTRIAL  
TANK WASHING  
SYSTEMS**



# PNR ITALIA

## SPRAY NOZZLES FOR INDUSTRIAL APPLICATIONS

PNR ITALIA manufactures and markets small spraying nozzles for individual use up to spraying systems for large industrial plants and is able to meet every customer's need with targeted solutions.

The wide range of products includes spray nozzles, washing heads and complementary accessories such as filters, guns and hoses for industrial washing, ejectors, blow nozzles, joints and hose clamps.

Located in Voghera, not far from Milan, the Headquarter and production plant is located in a strategic area favored by the proximity to the main motorway networks and important international maritime routes, easily accessible from the port of Genoa.

PNR ITALIA started its activity in 1968 with the trade and production of components and spraying nozzles for fire protection systems and, subsequently, with a range of sprayers for industrial applications. Over time it has grown and consolidated through a commercial policy based on a widespread network of partners present in the main foreign markets and also thanks to a continuous investment in research.

Today PNR ITALIA has at its disposal a technologically advanced production plant for the production of spraying nozzles, washing heads and atomizers with absolute quality machines, many of which work with CNC technology, often internally designed for special machining.

With an annual production of about 9 million pieces, PNR ITALIA is a solid industrial reality oriented to constant growth, driven by high-tech investments and product innovation.



# CONTENT

2	TANK WASHING TECHNIQUES
4	APPLICATIONS
6	FIXED SPRAY HEADS
11	SINGLE AXIS HEADS
12	REACTION DRIVE
20	MOTOR DRIVE
21	TWIN AXIS HEADS
23	AUXILIARY WASHING EQUIPMENTS
26	HIGH-PRESSURE DEVICES
29	SPECIAL PRODUCTS
33	SUMMARY TABLE
34	TECHNICAL INFORMATION
35	GENERAL INFORMATION





# TANK WASHING TECHNIQUES

The continuous research for higher efficiency in all kind of industries, and the requirement to assure a constant and higher quality level for their products, highlight the necessity that every step in the production, stocking and transporting processes are performed using adequately clean systems and tanks.

At the same time, as disposing of liquid effluents is becoming more and more costly, it becomes necessary that each cleaning process, while reaching a totally satisfactory result, is performed using the lowest possible volume of cleaning solution.

The two above factors have originated the introduction on the market of an always wider variety of tank cleaning devices, ranging from the classic fixed head to more and more sophisticated models to cope with the most demanding applications.

Our long experience in the field of tank cleaning suggests that the following basic concepts are given proper consideration in order to determine the correct washing cycle for each single application, and consequently the most suitable type of tank cleaning device.

## 1 PROPER FILTERING FOR THE WASHING LIQUID

Small inner passages and precision machined parts are typically found in tank washing equipment. In such cases where the washing cycle is performed by means of a recycled solution the solid particles which may be dispersed into the solution must be characterized for dimension and properties. Since suspended solid particles may affect proper operation of tank washing equipment, or require more frequent cleaning or service of the same, we suggest that a suitable line filter be considered.

## 2 CORRECT CHOICE FOR WASHING CYCLE AND SOLUTION

Based on the type of product which has to be eliminated, each single process has to be examined in order to define such parameters as the appropriate washing fluid, the right temperature, jet pressure and washing time of every phase.

## 3 ADEQUATE MOTIVE MECHANISM

The number of products which need to be removed from the wall of a tank is near to endless, each one showing its own different properties. Washing cycles can range from a quick water rinse at low pressure and ambient temperature, to long lasting cycles using hot water and caustic, sometimes at high pressure. The latter situation requires both a slow motion of the fluid jets, which have to hit the tank wall without breaking into drops and loose their impact, and a properly indexed rotation so that the revolving jets do not hit the same path at each turn.

Our tankwashers range, the most complete on the market, is classified by number of rotation axis and type of motive mechanism.

## 4 CLEANING RADIUS / WETTING RADIUS

It is not possible to define the cleaning radius of any tank washing equipment without making reference to precise conditions as the product to be eliminated, the cleaning fluid, the operating pressure and temperature.

Such value can only be determined by experience, for each single given process. It is instead possible to define a wetting radius, as the radius where the equipment can wet the entire tank inner surface: in this condition it must be expected the fluid to hit the wall with a small fraction of its original impact force.

We are available to put our experience at your service, and advise you in choosing the equipment that best suits your needs.

## EFFICIENCY ASSESSMENT

It is very difficult to assess such value as the efficiency range with reference to a given tank washing device without taking into consideration the various parameters relating to the process conditions, such as the materials you have to remove, working temperature and pressure, the time of every washing cycle.

While choosing a tank washing head, you have to consider if:

- the wetting radius is adequate for the dimension of the tank
- the capacity can provide the whole inner surface with a correct amount of washing solution for square measure;
- the impact force of the jet and the time required to complete a cleaning cycle are adequate for the product and/or process.

While taking in consideration all these elements, PNR Italia can suggest one or more suitable tank washing heads, depending on the specific case.

## CLEANING VALIDATION

This is the process whereby the desired cleaning condition is verified by means of a repeatable technique supplying results easily readable and according to the quality control requirements. There are two main verification you can do, in order to have a correct validation:

### ADEQUATE DISTRIBUTION OF THE SPRAY ON THE SURFACE OF THE TANK

It's common to spray the inner surface of the tank with Riboflavin, then to complete a cleaning cycle, and therefore to examine with an ultraviolet lamp that every trace of Riboflavin has been eliminated. Riboflavin is easily miscible with water at ambient temperature and should be completely eliminated from the surface when the same is satisfactorily covered by the washing jets. Traces of Riboflavine still sticking to the surface are revealed through an ultra-violet long wave light, and indicate areas not properly covered from the washing operation.

### ABSENCE OF ORGANIC RESIDUE

Cleaning operations tend to eliminate proteins spots of animal/vegetable origin, nourishment for microorganisms that facilitate the development of bacteria and retrain active molecules. The variety of possible cases and of existing regulations is such that the validation methodology is examined on a case-by-case basis. For example, a very common the technique is ATP-metry to count bacteria, which is based on ATP (Adenosine triphosphate, source of energy present in all living cells): the degradation reaction of ATP produces photons, whose intensity it is proportional to the amount of ATP present, and therefore the measurement of luminous intensity with a luminometer gives information on the quantity of cells present, and therefore on the cleaning condition of the tank.

## DEFINITIONS

### ATEX

ATEX, from the French words atmosphères and explosives (in Italian: "explosive atmospheres"), is the conventional name given to the European Union Directive 2014/34/EU for the regulation of equipment intended for use in areas at risk of explosion.

ATEX MARKING:

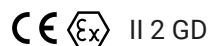

### 3-A

The 3-A Sanitary Standards is an American standard that regulates the design and manufacture of food contact equipment. 3-A aims to protect the individual from risks related to potential food contamination.

### SINGLE AXIS HEADS

It's a device where the moving part is rotating around the vertical axis of the feed pipe. They are more suitable to wash products with low resistance.

### TWIN AXIS HEADS

It's a device where the washing nozzles rotate around an horizontal axis, while the tankwasher body carrying the nozzles rotates at the same time around the vertical axis of the feed pipe. They allow stronger washing actions.

### FDA APPROVED

With this sentence, we confirm that the materials used for manufacturing the products fall within the list of the FDA and CE 1935/2004 approved food grade materials. Among them we have AISI 316L, PTFE, PEEK.

### SPRAY COVERAGE











It is the solid angle covered by the jets, with an origin in the point of the tank washer at the water inlet, and defined as follows:

- the reference direction is the one of the fluid in the inlet connection;
- the direction of the jet is DOWN when it is concurrent to the reference direction;
- the direction of the jet is UP when it is opposite to the reference direction.

### MOCA

Declaration of Conformity for MOCA (Materials and Objects in Contact with Food) is a certification necessary to ensure compliance with certain requirements, production and raw materials, mandatory in terms of food hygiene and according to CE 1935/2004.

# WASHING HEADS APPLICATIONS

	INDUSTRY	RESIDUES CLEANED
	CHEMICAL, PAINTS & COATINGS	<ul style="list-style-type: none"> <li>PAINTS</li> <li>PLASTICS</li> <li>RESINS</li> <li>ADHESIVES</li> <li>SEALANTS</li> <li>LATEX</li> <li>ACRYLICS</li> </ul>
	FOOD AND BEVERAGE INDUSTRY	<ul style="list-style-type: none"> <li>DAIRY</li> <li>JUICES</li> <li>SAUCES</li> <li>SUGARS</li> <li>SOUPS</li> <li>FROZEN FOOD INGREDIENTS</li> </ul>
	PHARMACEUTICAL INDUSTRY	<ul style="list-style-type: none"> <li>MEDICINES</li> <li>POWDERS</li> <li>ACTIVE INGREDIENTS</li> </ul>
	PULP AND PAPER INDUSTRY	<ul style="list-style-type: none"> <li>PAPER STOCK</li> <li>INKS</li> <li>COLORS</li> </ul>
	ETHANOL	<ul style="list-style-type: none"> <li>YEAST SLURRY</li> <li>CORN MASH</li> </ul>
	COSMETIC INDUSTRY	<ul style="list-style-type: none"> <li>SHAMPOO</li> <li>LOTION</li> <li>CRÈMES</li> <li>OILS</li> <li>COSMETICS</li> <li>PERFUMES</li> </ul>
	WINEMAKING INDUSTRY	<ul style="list-style-type: none"> <li>WINE</li> <li>SPICES</li> <li>SUGARS</li> </ul>
	BREWERY INDUSTRY	<ul style="list-style-type: none"> <li>MALT</li> <li>YEAST</li> <li>MASH</li> <li>WORT</li> <li>BEER</li> </ul>
	TRANSPORTATION	<ul style="list-style-type: none"> <li>ORANGE JUICE</li> <li>DAIRY PRODUCTS</li> <li>FOOD INGREDIENTS</li> <li>OIL</li> <li>CHEMICALS</li> </ul>
	SHIPBUILDING INDUSTRY	<ul style="list-style-type: none"> <li>ORGANIC SEWAGE</li> <li>SEAWEED</li> </ul>

EQUIPMENT TYPES		TANK CLEANING HEADS USED			
MIXERS/BLENDERS REACTORS PROCESS TANKS	STORAGE TANKS TOTES DRUMS	UBB UBT	UKD UKR	UBR	
COOKERS/FRYERS STORAGE TANKS RAIL CARS	KETTLES MIXERS/BLENDERS SPRAY DRY TOWERS	UA3 UBB UBC	UBD UBF UBT	UBX UKD UKK	UKR
BLENDERS FERMENTERS TOTES/DRUMS	STORAGE CONTAINERS SPRAY DRY TOWERS	UAC UBA	UBB UBC UBD	UBF UBT UBX	UKD UKR
BROKE CHESTS STOCK CHESTS TOTES/CONTAINERS TANK TRAILERS		UBA UBB UBC	UBT CH		
FERMENTERS YEAST TANKS STORAGE TANKS TANK TRAILERS		UBT			
MIXERS BLENDERS KETTLES	DRYERS VESSELS STORAGE TANKS	UBB UBC UBT	UKD UKR		
FERMENTERS BARRELS KEGS WINE STORAGE		UA3 UBB	UBF UBT	UKD UKK UKR	
FERMENTERS BREW KETTLES MASH TANKS	STORAGE TANKS HOT WORT RECEIVERS	UBT UBX	UKD UKK UKR		
WET/DRY BULK TRANSPORT TRAILERS RAIL CARS TOTES	IBC'S ISO TANKS/CONTAINERS	UBT UBQ	UKD UKR	UBR	
BLACK CHAMBER WASHING TANK PURIFICATION TANK SANITATION		UBC			

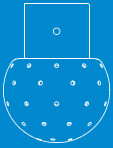

# FIXED SPRAY HEADS

The most simple tank washing devices, fixed heads or spray balls are the classic equipment used in thousands of tanks for their reliability and since easily kept in perfect hygienic conditions.

Their low impact properties and high volume fluid requirement limit their use to small tank sizes and processes where easily cleaned liquids and non sticking products have to be eliminated.

Our models UA3, UAB and UAC are made out of high quality stainless steel and cover most possible applications, while we are still pleased to quote for special models designed on individual requirements.



## ANGLES COVERAGE

The coverage angles mentioned in this Catalog are intended for fixed or rotating balls mounted on the top of the tank and spraying downwards. Therefore when we speak of UP and DOWN we always mean jets directed towards the upper and lower parts of the tank with the washing device mounted on the upper part of the tank. The letter indicating the coverage angle value is the penultimate of the product code.

## CONNECTIONS SIZE

Washing devices are often supplied with clip connections that make disassembly operations quick and easy to clean the component, alternatively they are also available in the version with solder connection.

# UA3

UA3 tank washing heads are the most advanced hygienic devices available for applications in food industry. Designing and realization follow 3-A Sanitary Standard. The electropolishing finish assures a roughness Ra < 0,8 µm required for the devices used in food processing. Used materials follow standard EC 1935/2004 and come under the list of materials indicated by FDA for food application.

MATERIAL: B31 AISI 316L STAINLESS STEEL

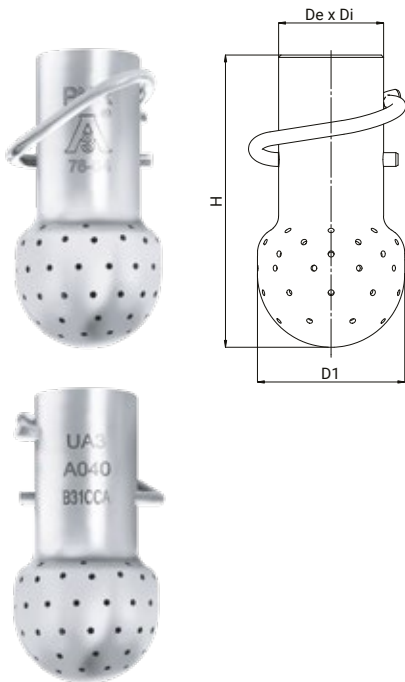

CODE	Connection De x Di (mm x mm)	Connection pipe Standard DIN 11866	D1 mm	Capacity m3/h 1 bar	Coverage	Dia mm	H mm	WR m
UA3 A040 B31ACA	22,8 x 19,8	DN 15 File A	32	4,00	180°UP	1,3	63,5	1,7
UA3 C056 B31ACA	32,8 x 29,8	DN 25 File A	50	5,60		2,0	100	2,2
UA3 D098 B31ACA	44,8 x 41,8	DN 40 File A	65	9,80		2,5	117	2,7
UA3 A040 B31BCA	22,8 x 19,8	DN 15 File A	32	4,00	180°DOWN	1,3	63,5	2,0
UA3 C056 B31BCA	32,8 x 29,8	DN 25 File A	50	5,60		2,0	100	2,5
UA3 D098 B31BCA	44,8 x 41,8	DN 40 File A	65	9,80		2,5	117	3,0
UA3 A040 B31CCA	22,8 x 19,8	DN 15 File A	32	4,00	270°UP	1,3	63,5	1,5
UA3 C056 B31CCA	32,8 x 29,8	DN 25 File A	50	5,60		2,0	100	2,0
UA3 D098 B31CCA	44,8 x 41,8	DN 40 File A	65	9,80		2,5	117	2,5
UA3 A026 B31ECA	22,8 x 19,8	DN 15 File A	32	2,60	360°	1,3	63,5	1,0
UA3 C056 B31ECA	32,8 x 29,8	DN 25 File A	50	5,60		2,0	100	1,5
UA3 D193 B31ECA	44,8 x 41,8	DN 40 File A	65	19,3		2,5	117	2,0

Read more about 3-A certification at the end of the catalog.

# UAB

UAB heads are very compact devices, for applications like pipe washing or for cleaning tight spaces. The thick walls of this device, which is machined from solid stainless steel rod, make it also a good choice where the washing process needs to be performed at high pressure values.

MATERIAL: B1 AISI 303 STAINLESS STEEL  
B31 AISI 316L STAINLESS STEEL

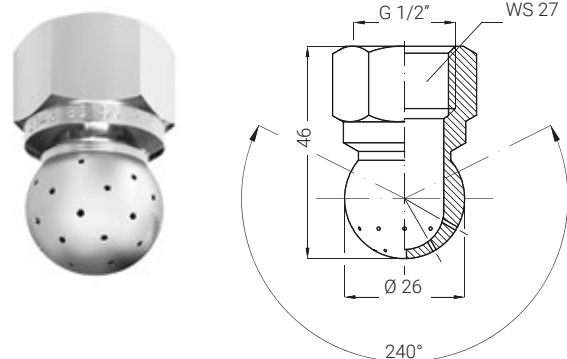

BSP thread

CODE	Dia mm	D mm	Capacity at different pressure values			
			2,0	3,0	4,0	5,0
UAB 2220 xxSG	0,8	26	18,0	22,0	25,3	28,5
UAB 2343 xxSG	1,0		28,0	34,3	39,5	44,3
UAB 2700 xxSG	1,5		57,0	70,0	80,5	90,3
UAB 3110 xxSG	2,0		90,0	110	126	142
UAB 3145 xxSG	2,3		118	145	167	187

# UAC

UAC fixed spray heads are a simple, fast and efficient device for cleaning the inside of small size tanks where a simple rinsing action is required. Because of the relatively high washing fluid flow rate, they are usually operated at low pressures and can achieve a limited impact action on the tank wall. Their simple design allows for the head to be easily cleaned after being operated, which makes it possible to leave the heads permanently in place ready for use. The values for wetting radiuses shown at the right of the table have been obtained operating the heads with a water pressure value of 1 bar. On request, heads with electropolishing  $Ra < 0,8 \mu m$  are available, in order to have roughness for alimentary applications.

MATERIAL:	31	AISI 316L STAINLESS STEEL	CONNECTION:	FEMALE THREAD (BSPP - NPT);
	L8	HASTELLOY C267 (ON REQUEST)		CLIP-ON; WELDED.
	H1	TITANIUM GR2 (ON REQUEST)		

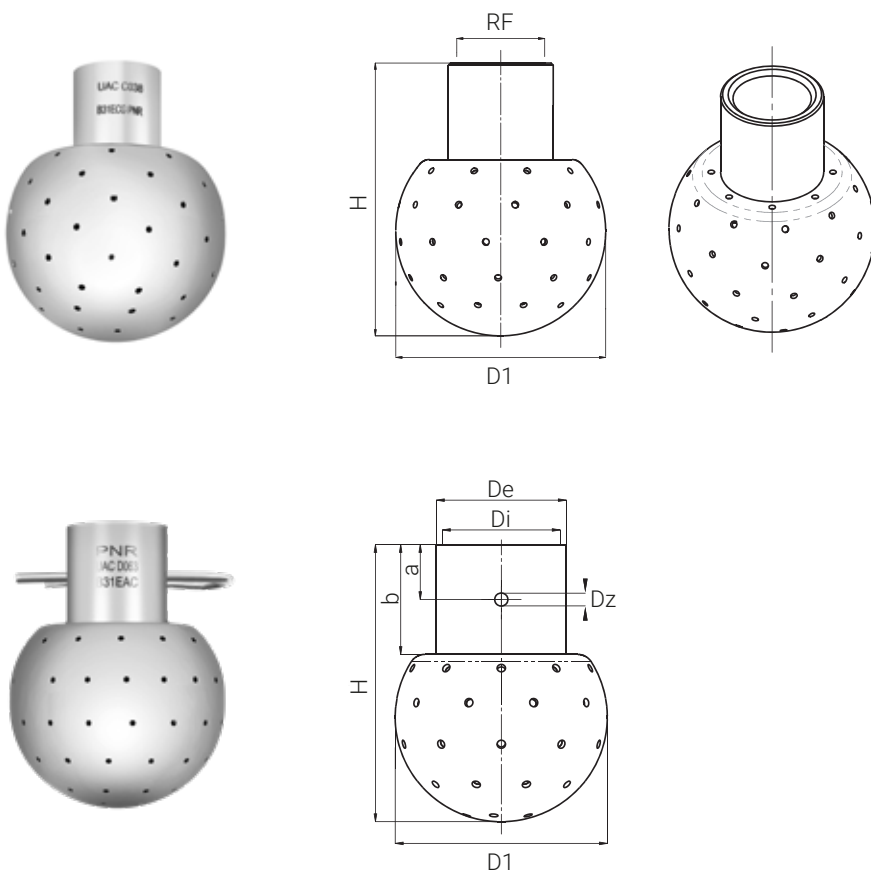

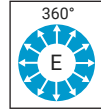
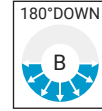
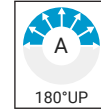

CODE	SPHERE DIAMETER	Flow rate				Coverage deg			COVERAGE CODE	THREADED CONNECTION	THREADED CONN. CODE	THREAD TYPE BSPP/NPT	CLIP-ON CONNECTION	CLIP-ON CONN. CODE	CONNECTION TYPE	WELDED CONNECTION	WELDED CONN. CODE	CONNECTION TYPE
		m³/h@ 1 bar	l/min @			360	180u	180d										
			1 bar	2 bar	3 bar													
UAC A018 B31EBG	30	1,80	30,0	42,4	52,0	•			E	1/4	B	G						
UAC A012 B31ABG	30	1,20	20,0	28,3	34,6		•		A	1/4	B	G						
UAC A014 B31BBG	30	1,40	23,3	33,0	40,4			•	B	1/4	B	G						
UAC A018 B31EBC	30	1,80	30,0	42,4	52,0	•			E				22x20	B	C			
UAC A012 B31ABC	30	1,20	20,0	28,3	34,6		•		A				22x20	B	C			
UAC A014 B31BBC	30	1,40	23,3	33,0	40,4			•	B				22x20	B	C			
UAC A018 B31EAW	30	1,80	30,0	42,4	52,0	•			E							22x20	A	W
UAC A012 B31AAW	30	1,20	20,0	28,3	34,6		•		A							22x20	A	W
UAC A014 B31BAW	30	1,40	23,3	33,0	40,4			•	B							22x20	A	W
UAC C054 B31EDG	50	5,40	90,0	127	156	•			E	1/2	D	G						
UAC C030 B31ADG	50	3,00	50,0	70,7	86,6		•		A	1/2	D	G						
UAC C030 B31BDG	50	3,00	50,0	70,7	86,6			•	B	1/2	D	G						
UAC C054 B31EFC	50	5,40	90,0	127	156	•			E				22x20	F	C			
UAC C030 B31AFC	50	3,00	50,0	70,7	86,6		•		A				22x20	F	C			
UAC C030 B31BFC	50	3,00	50,0	70,7	86,6			•	B				22x20	F	C			
UAC C054 B31EDC	50	5,40	90,0	127	156	•			E				28x26	D	C			
UAC C030 B31ADC	50	3,00	50,0	70,7	86,6		•		A				28x26	D	C			
UAC C030 B31BDC	50	3,00	50,0	70,7	86,6			•	B				28x26	D	C			
UAC C054 B31EAW	50	5,40	90,0	127	156	•			E							22x20	A	W
UAC C030 B31AAW	50	3,00	50,0	70,7	86,6		•		A							22x20	A	W
UAC C030 B31BAW	50	3,00	50,0	70,7	86,6			•	B							22x20	A	W
UAC C054 B31EGW	50	5,40	90,0	127	156	•			E							28x26	G	W
UAC C030 B31AGW	50	3,00	50,0	70,7	86,6		•		A							28x26	G	W
UAC C030 B31BGW	50	3,00	50,0	70,7	86,6			•	B							28x26	G	W
UAC D132 B31EEG	65	13,2	220	311	381	•			E	3/4	E	G						
UAC D087 B31AEG	65	8,70	145	205	251		•		A	3/4	E	G						
UAC D092 B31BEG	65	9,20	153	217	266			•	B	3/4	E	G						
UAC D132 B31EDC	65	13,2	220	311	381	•			E				28x26	D	C			
UAC D087 B31ADC	65	8,70	145	205	251		•		A				28x26	D	C			
UAC D092 B31BDC	65	9,20	153	217	266			•	B				28x26	D	C			
UAC D132 B31EAW	65	13,2	220	311	381	•			E							28x26	A	W
UAC D087 B31AAW	65	8,70	145	205	251		•		A							28x26	A	W
UAC D092 B31BAW	65	9,20	153	217	266			•	B							28x26	A	W
UAC E371 B31EGG	90	37,0	617	872	1068	•			E	1-1/4	G	G						
UAC E209 B31AGG	90	21,0	350	495	606		•		A	1-1/4	G	G						
UAC E209 B31BGG	90	21,0	350	495	606			•	B	1-1/4	G	G						
UAC E371 B31EGC	90	37,0	617	872	1068	•			E				54,5X52,5	G	C			
UAC E209 B31AGC	90	21,0	350	495	606		•		A				54,5X52,5	G	C			
UAC E209 B31BGC	90	21,0	350	495	606			•	B				54,5X52,5	G	C			
UAC E371 B31ELW	90	37,0	617	872	1068	•			E							54,5X52,5	L	W
UAC E209 B31ALW	90	21,0	350	495	606		•		A							54,5X52,5	L	W
UAC E209 B31BLW	90	21,0	350	495	606			•	B							54,5X52,5	L	W

# CH

CH series includes large and small capacities full cone cluster nozzles. They make a cluster spray pattern and are available in 7 and 13 nozzles versions. Several nozzles are assembled on one nipple with small volume and wide spray coverage. The droplets size is 1/3-1/2 compared to those produced by a single nozzle with same capacity. An added value to CH full cone nozzle is their wide spray range.

MATERIAL: B1 AISI 303 STAINLESS STEEL      THREAD: STANDARD BSP  
 B31 AISI 316L STAINLESS STEEL      STANDARD NPT  
 T1 BRASS



CH

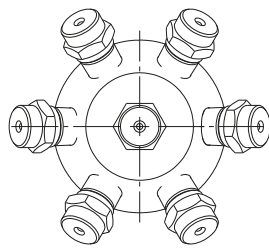

BOTTOM VIEW

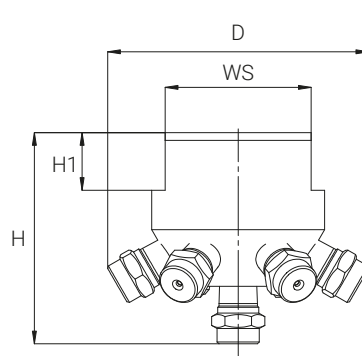

MODEL WITH 7 NOZZLES

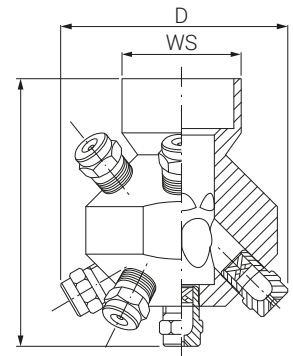

MODEL WITH 13 NOZZLES

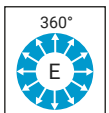
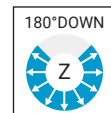

Threaded connections

CODE	Capacity at different pressures l/min bar					Spray coverage deg		RF BSP				Dimensions mm				Number of nozzles
	1,0	2,0	3,0	5,0	10	180	360	3/4"	1"	1-1/2"	2"	D	WS	H	H1	
CHZ 1826 xx	4,77	6,47	8,26	10,7	15,1	•		•				68	38	55	15	7
CHZ 2165 xx	9,53	13,5	16,5	21,3	30,1	•		•								
CHZ 2329 xx	19,0	26,9	32,9	42,5	60,1	•			•			71,5	46	68	17	
CHZ 2585 xx	33,8	47,8	58,5	75,5	106	•			•							
CHZ 2819 xx	47,3	66,9	81,9	106	150	•			•							
CHZ 3102 xx	59,4	84,0	102	133	188	•				•		128	70	93	20	
CHZ 3131 xx	76,0	107	131	170	240	•				•						
CHZ 3206 xx	119	168	206	267	377	•					•	171	85	122	27	
CHZ 3259 xx	149	211	259	334	473	•					•					
CHZ 3329 xx	190	268	329	425	600	•					•					
CHE 2153 xx	8,83	12,5	15,3	19,8	27,9		•	•				69	39	85	-	13
CHE 2306 xx	17,7	25,0	30,6	39,5	55,9		•	•								
CHE 2611 xx	35,3	49,9	61,1	78,9	111		•		•			86	48	105	-	
CHE 3108 xx	62,7	88,7	108	140	198		•		•							
CHE 3152 xx	87,8	124	152	196	277		•		•							
CHE 3191 xx	110	156	191	246	349		•			•		98	55	120	-	
CHE 3245 xx	141	200	245	316	447		•			•						
CHE 3383 xx	221	313	383	495	700		•				•	129	73	159	-	
CHE 3481 xx	277	392	481	621	878		•				•	169	95	206	-	



# SINGLE AXIS HEADS

## REACTION DRIVE

The washing action is obtained through water jets coming from a rotating head, where the head motion is obtained purely through reaction force originated by the fluid jets being ejected.

The operating pressure influences the head rotation speed, which must be limited to avoid the water jets being broken into minute droplets and losing part of their impact force.

These devices perform very satisfactorily in a great number of general applications, where the products to be washed away do not originate severe problems and with limited size tanks.

To cope with the large variety of industrial applications we offer heads made out completely of stainless steel, out of PTFE, PVDF or a mix of those materials.

Connections are obtained through female thread or easy to clean clip fix slip-on pipe

## MOTOR DRIVE

A further step in performance with one axis heads performance is obtained with a design where a very simple friction motor provides for low speed rotating head.

This design offers a remarkable advantage because of the lower rotation velocity: the jets remain coherent without being broken into droplets by centrifugal force and all of their impact energy can be transferred to the tank surface



# UB3 A

The rotating tank cleaning nozzle UB3 A is a 3-A certified washing device according to standard 78-04, the US regulation governing the design and production of equipment intended for food contact. The UB3 A washing devices are made of stainless steel AISI 316L EN 1.4404 and PEEK + 10% PTFE (only for the rotating element). This material ensures excellent mechanical characteristics and sliding properties. The cleaning equipment is suitable for use with products commonly used in CIP (*Clean-In-Place*) processes and compatible with AISI 316L and PEEK.

It cannot be used with fluids or substances that could be aggressive towards AISI 316L and PEEK.

The main application of the UB3 A is tank washing in the general food industry, particularly in the dairy and beverage sectors. This intended use and compliance with the 3-A standard determine two fundamental characteristics of the UB3 A: *ease of assembly and disassembly* and *self-cleaning of internal parts* (for which the head must be installed vertically, because horizontal installation does not guarantee complete emptying of the device).

MATERIAL: B31 AISI 316L STAINLESS STEEL  
T1 PEEK + 10% PTFE

CONNECTION: CLIP-ON FOR PIPES Ø19  
(DIN 11866 RANGE A)

Washing liquid  
for ATEX products  
 $T \leq 90^{\circ}\text{C}$

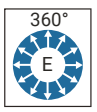

Clip connection

CODE	COVERAGE	FLOW RATE (lpm) @ 3 bar	H	H1	ØDE	ØOD	ØID
UB3 A040 B31EC	360°	40	94	22	38	24	19,3
UB3 A050 B31EC		50	94	22	38	24	19,3
UB3 A075 B31EC		75	94	22	38	24	19,3
UB3 A100 B31EC		100	94	22	38	24	19,3

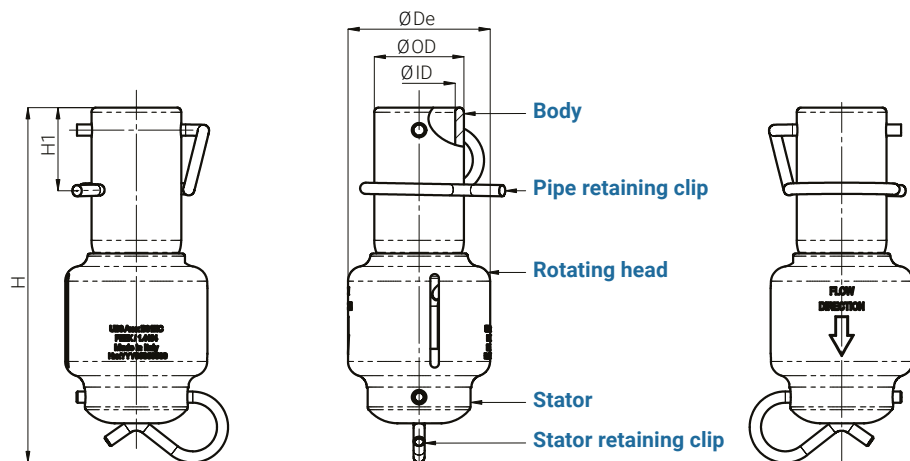

# UBB

UBB heads are specially designed for applications where chemical attack from strong acids is to be expected, or when contamination to the product being handled is to be excluded, and are therefore entirely made out of PTFE.

Their rotary motion is produced from the reaction forces of their solid stream water jets, which are arranged in such a way that the inner tank surface is thoroughly covered when the head rotor is in motion. The simple design, a two-piece construction, assures for long, maintenance free service. The wide range of capacities and the choice among several spray patterns makes it easy to find the right product to suite a variety of different applications. The codes shown in the capacity table refer to BSP threads.

Our offices can supply coding for products designed with NPT threads.

MATERIAL: E1 PTFE (FDA APPROVED)

BSP / NPT  
thread connection

LT: 90° C  
LP: 4.0 BAR

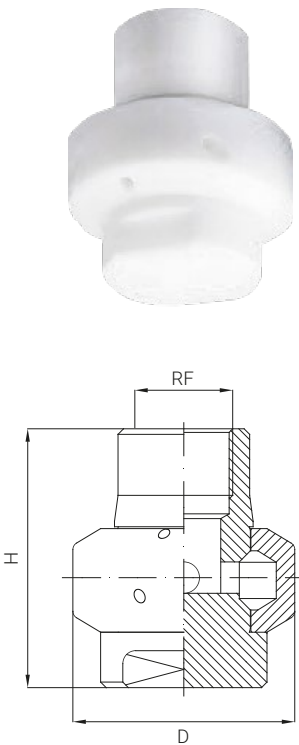
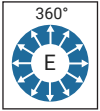
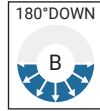
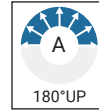

CODE	RF BSP	Capacity at different pressures					Dimensions mm	
		1,5	2,0	2,5	3,0	3,5	H	D
UBB 0003 E1xG	1/2"	21,5	24,7	27,5	30,0	32,3	60	50
UBB 0004 E1xG	3/4"	22,9	26,3	29,3	32,0	34,5	70	60
UBB 0007 E1xG		50,2	57,6	64,1	70,0	75,4		
UBB 0012 E1xG		86,0	98,8	110	120	129		
UBB 0018 E1xG		130	150	167	182	196		
UBB 0020 E1xG	1"	143	165	183	200	215	75	70
UBB 0027 E1xG		197	225	252	275	296		
UBB 0035 E1xG		255	292	325	355	382		
UBB 0039 E1xG	2"	283	325	362	395	425	110	125
UBB 0049 E1xG		355	407	454	495	533		
UBB 0059 E1xG		423	486	541	590	635		
UBB 0069 E1xG		495	568	632	690	743		
UBB 0098 E1xG	3"	706	811	902	985	1061	150	175
UBB 0118 E1xG		846	971	1081	1180	1271		
UBB 0138 E1xG		989	1136	1264	1380	1486		

In order to obtain the complet code of the tank washing head, you need to change the "x" letter, in second to last position, with the corresponding letter concerning the spray coverage, among the ones available.

# UBC M007 B31BEG | UBC M023 B31DEB

This family of washing heads consists of the smallest models in the UBC range (see next page). They are obtained from machined steel and designed with similar geometry, differing only in size. Mainly used for washing small ovens, the two available sizes have threaded connection available both BSP (the smallest) and BSPT (the largest). If required, the NPT connection is also available.

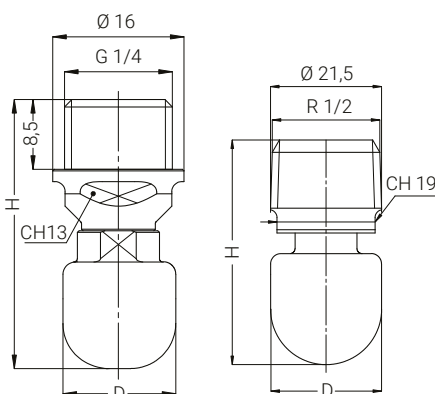

MATERIAL: B31 AISI 316L S.S.  
L61 ALLOY C22

Washing liquid  
for ATEX products  
T ≤ 90°C

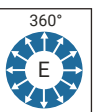
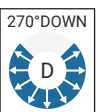
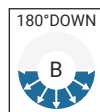
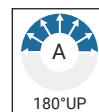

Threaded male connection

CODE	Capacity l/min at pressure bar				Coverage deg				RG BSP BSPT NPT			Dimens. mm	
	2,0	3,0	5,0	7,0	360	270u	270d	180d	BSP	BSPT	NPT	H	D
UBC M007 B31BEG	5,7	7,0	9,0	10,7	•				1/4" BSP			32,8	14
UBC M023 B31DEB	18,9	23,0	29,4	34,5	•				1/2" BSPT			43,5	21,5

# UBC

The UBC tank cleaning nozzles are made entirely of stainless steel, with the shaft mounted on a double ring of steel balls, allowing use in any position. The internal and external surfaces are machined and deburred, and undergo meticulous finishing cycles to achieve a predefined surface roughness designed to minimize the risk of contamination from bacterial growth. Their primary application is in cleaning canisters and tanks in the food industry, although they can also be used in various other applications. The UBC cleaning nozzle is typically supplied with a female threaded connection or a clip-on connection but is also available upon request with a weld-on connection, NPT connection, or tri-clamp fittings (note that with this configuration, the device cannot be ATEX certified). Starting in 2025, all UBC cleaning heads we manufacture will be certified for food contact in accordance with Framework Regulation 1935/2004 and Regulation 2023/2006. Upon request, they can also be ATEX certified.



MATERIAL: B31 AISI 316L STAINLESS STEEL  
L61 ALLOY C22

Washing liquid for ATEX products T ≤ 90°C



Female BSP or NPT Thread

CODE	Dimens. mm		Flow rate at pressure l/min bar		Coverage deg code letter X					Threaded connection (RF) code letter Y G=BSP N=NPT						
	D	H	3,0	5,0	A	B	C	D	E	3/8"	1/2"	3/4"	1"	1 1/4"		
UBC 2100 B31xy CA	25	55	10	12,9	•	•	•	•	•	■						
UBC 2200 B31xy CA			20	25,8	•	•	•	•	•	■						
UBC 2300 B31xy CA			30	38,7	•	•	•	•	•	•	■					
UBC 2480 B31xy CA			48	62	•	•	•	•	•	•	■					
UBC 2629 B31xy CA	45	115	63	81,3	•	•	•	•	•		■					
UBC 2630 B31xy CA			63	81,3	•	•	•	•	•			■				
UBC 2899 B31xy CA			90	116	•	•	•	•	•			■				
UBC 2900 B31xy CA			90	116	•	•	•	•	•				■			
UBC 3120 B31xy CA			120	155	•	•	•	•	•					■		
UBC 3135 B31xy CA			135	174	•	•	•	•	•						■	
UBC 3178 B31xy CA			178	230	•	•	•	•	•							■
UBC 3215 B31xy CA			215	277	•	•	•	•	•							
UBC 3300 B31xy CA	65	131	300	458	•	•	•	•	•							■

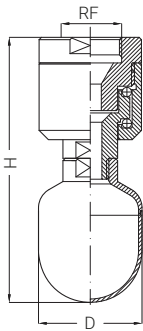

UBC threaded connect.

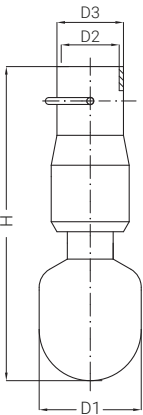

UBC clip-on connection

Clip-on connection

Available on request with American pin. Last letter of the code: D insted of C

CODE	Dimens. mm		Flow rate at pressure l/min bar		Coverage deg code letter X					Clip-on connection D3 x D2 (Standard) mm code letter Y					
	D1	H	3,0	5,0	A	B	C	D	E	C	D	E	H		
UBC 2100 B31xy CA	25	70	10	12,9	•	•	•	•	•		22x20	/	/	/	
UBC 2200 B31xy CA			20	25,8	•	•	•	•	•		22x20	/	/	/	
UBC 2300 B31xy CA			30	38,7	•	•	•	•	•		22x20	/	/	/	
UBC 2480 B31xy CA			48	62	•	•	•	•	•		22x20	/	/	/	
UBC 2630 B31xy CA	45	135	63	81,3	•	•	•	•	•		29x25,3	29x25,7	31,5x27,5	29x25,4	
UBC 2900 B31xy CA			90	116	•	•	•	•	•		29x25,3	29x25,7	31,5x27,5	29x25,4	
UBC 3120 B31xy CA			120	155	•	•	•	•	•		29x25,3	29x25,7	31,5x27,5	29x25,4	
UBC 3135 B31xy CA			135	174	•	•	•	•	•		29x25,3	29x25,7	31,5x27,5	29x25,4	
UBC 3178 B31xy CA			178	230	•	•	•	•	•		29x25,3	29x25,7	31,5x27,5	29x25,4	
UBC 3215 B31xy CA			215	277	•	•	•	•	•		44x38,5	/	/	38,5x35,5	
UBC 3300 B31xy CA			65	159	300	458	•	•	•	•		44x38,3	/	/	38,5x35,5

Welded connection

CODE	Dimens. mm		Portata alla pressione l/min bar		Coverage deg code letter X					Welded connection D3 x D2 (Standard) mm code letter Y				
	D1	H	3,0	5,0	A	B	C	D	E	W	S	V	R	
UBC 2100 B31xy CA	25	69	10	12,9	•	•	•	•	•	19,05x15,75 (DIN 11866/C)	12,7x9,4 (DIN 11866/C)	/	/	
UBC 2200 B31xy CA		69	20	25,8	•	•	•	•	•	19,05x15,75 (DIN 11866/C)	12,7x9,4 (DIN 11866/C)	/	/	
UBC 2300 B31xy CA		78	30	38,7	•	•	•	•	•	19,05x15,75 (DIN 11866/C)	12,7x9,4 (DIN 11866/C)	/	/	
UBC 2480 B31xy CA		78	48	62	•	•	•	•	•	19,05x15,75 (DIN 11866/C)	12,7x9,4 (DIN 11866/C)	/	/	
UBC 2630 B31xy CA	45	250	63	81,3	•	•	•	•	•	25,4x22,1 (DIN 11866/C)	25x21 (EN 10217-7)	29x26 (DIN 11866/A)	25x22,6 (SMS 3008)	
UBC 2900 B31xy CA			90	116	•	•	•	•	•	25,4x22,1 (DIN 11866/C)	25x21 (EN 10217-7)	29x26 (DIN 11866/A)	25x22,6 (SMS 3008)	
UBC 3120 B31xy CA			120	155	•	•	•	•	•	25,4x22,1 (DIN 11866/C)	25x21 (EN 10217-7)	29x26 (DIN 11866/A)	25x22,6 (SMS 3008)	
UBC 3135 B31xy CA			135	174	•	•	•	•	•	25,4x22,1 (DIN 11866/C)	25x21 (EN 10217-7)	29x26 (DIN 11866/A)	25x22,6 (SMS 3008)	
UBC 3215 B31xy CA			215	277	•	•	•	•	•	33,7x29,7 (EN 10217-7)	38x34 (EN 10217-7)	/	/	
UBC 3300 B31xy CA			65	131	300	458	•	•	•	•	33,7x29,7 (EN 10217-7)	38x34 (EN 10217-7)	/	/

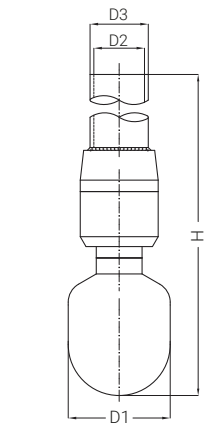

UBC welded connection

# UBD

UBD rotary heads can profit from the special design of their rotary head, which allows for a very even water distribution, assuring optimum surface coverage. They assure therefore very short washing cycles, using lower quantities of water, with a definite advantage in those applications where recycled water is not allowed as a washing medium, and the volumes sent to disposal must be kept to a minimum. UBD heads work using Teflon slide bearings floating at high speed over a thin water film, the only wear part being an easily replaceable Teflon washer. Only a fraction of the liquid energy is then used to power the washing head, while the high speed of the rotating disc produces instantly a cloud of high energy droplets all over the inside surface of the tank. The clever design of this device results in no maintenance at all being necessary. The extremely simple design makes sanitizing quick and easy. Also available with NPT connection.

MATERIAL: BODY, SHAFT AND ROTARY HEAD B31 AISI 316L S.S.  
L61 ALLOY C22  
BEARINGS: E1 PTFE

Washing liquid for ATEX products  
T ≤ 90°C



BSP or NPT threaded connection

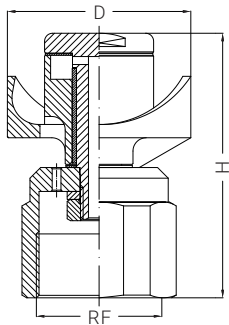

UBD 0140

CODE	Flow rate at different pressure l/min bar					Spray coverage deg			RG BSP				RF BSP				Dimensions mm	
	2,0	3,0	4,0	5,0	7,0	180°u	180°d	360°	1/4"		3/4"		1"		1-1/2"		H	D
UBD 0051 B31AG	41,0	50,0	58,0	64,0	76,0	.				.							55	35
UBD 0051 B31BG	41,0	50,0	58,0	64,0	76,0		.			.							55	38
UBD 0051 B31EG	41,0	50,0	58,0	64,0	76,0			.		.							55	38
UBD 0090 B31AG	73,0	90,0	104	116	137	.				.							75	50
UBD 0090 B31BG	73,0	90,0	104	116	137		.			.							75	50
UBD 0090 B31EG	73,0	90,0	104	116	137			.		.							75	50
UBD 0091 B31AG	73,0	90,0	104	116	137	.				.							100	70
UBD 0091 B31BG	73,0	90,0	104	116	137		.			.							100	70
UBD 0091 B31EG	73,0	90,0	104	116	137			.		.							100	70
UBD 0140 B31AG	114	140	162	181	214	.				.							75	50
UBD 0140 B31BG	114	140	162	181	214		.			.							75	50
UBD 0140 B31EG	114	140	162	181	214			.		.							75	50
UBD 0141 B31AG	114	140	162	181	214	.				.							100	70
UBD 0141 B31BG	114	140	162	181	214		.			.							100	70
UBD 0141 B31EG	114	140	162	181	214			.		.							100	70
UBD 0210 B31AG	171	210	242	271	321	.				.							100	70
UBD 0210 B31BG	171	210	242	271	321		.			.							100	70
UBD 0210 B31EG	171	210	242	271	321			.		.							100	70

Models with 3/4", 1", 1-1/2" connections can also be supplied with standard NPT thread: In these cases the value of H may vary slightly and the last letter of the product code will be N instead of G. The version in L61 differs from that in B31 only for the material of realization while the performance, size and connection methods remain the same.

Made without the need for bearings, they are the version of the **UBD range with a 1/4" BSP male thread**. The rotor completely in Teflon reduces friction to a minimum, eliminating any lubrication need. Because of its small size, this head is ideal for the internal washing of small tanks with not too viscous residues. Also available with NPT connection.

MATERIAL: HEAD B31 AISI 316L S.S.  
L61 ALLOY C22  
ROTOR E1 PTFE  
LOCK RING N1 AISI 302

Washing liquid for ATEX products  
T ≤ 90°C



BSP or NPT threaded connection

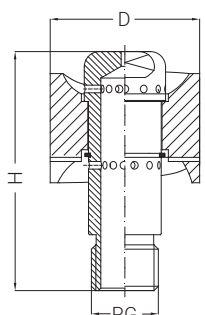

CODE	Flow rate at different pressure l/min bar					Spray coverage deg			RG BSP				RF BSP				Dimensions mm	
	2,0	3,0	4,0	5,0	7,0	180°u	180°d	360°	1/4"		3/4"		1"		1-1/2"		H	D
UBD 0035 B31AG	29,0	35,0	40,0	45,0	53,0	.				.							45	28
UBD 0035 B31BG	29,0	35,0	40,0	45,0	53,0		.			.							45	28
UBD 0035 B31EG	29,0	35,0	40,0	45,0	53,0			.		.							45	28
UBD 0050 B31AG	41,0	50,0	58,0	64,0	76,0	.				.							45	28
UBD 0050 B31BG	41,0	50,0	58,0	64,0	76,0		.			.							45	28
UBD 0050 B31EG	41,0	50,0	58,0	64,0	76,0			.		.							45	28

In case of NPT thread the last letter of the code will be N instead of G. The version in L61 differs from that in B31 only for the material of realization while the performances, the dimensions and the modalities of connection remain the same.

# UBD A

UBD A rotary heads are a simple but very efficient device for the inside cleaning of tanks. The rotary disk is rotated through the action of the cleaning fluid and produces a very dense spray which reaches all parts of the inside surface, it is the only mobile part of the unit and requires no servicing at all. No lubrication is required, and therefore no risk exists of contaminating your product with oil or grease. Ideally suited for aggressive environments, it operates efficiently with all detergents and chemical solutions, in both closed and open tanks because available with 360 or 180 degrees spray patterns. UBD A models find their application in pharmaceutical, chemical and food industries.

MATERIAL: E1 PTFE PURE (FDA APPROVED)  
 E11 PTFE + 15% GRAPHITE  
 D9 PEEK (FDA APPROVED)

LT: 95° C



Thread connection

CODE	Flow rate at different pressure					l/min bar	Copertura deg			RM BSP	RF BSP		Dimensions mm		
	2,0	3,0	4,0	5,0	6,0		360	180u	180d	1/4"	3/4"	1"	1-1/2"	H	D
UBD A035 xxEG*	28,6	35,0	40,5	45,2	49,5		•			•				47	30
UBD A051 xxEG	41,2	50,0	57,4	63,9	69,7		•				•			55	40
UBD A090 xxEG	73,5	90,0	104	116	127		•				•			49	40
UBD A090 xxAG	73,5	90,0	104	116	127			•							
UBD A090 xxBG	73,5	90,0	104	116	127				•						
UBD A140 xxEG	114	140	162	180	198		•					•		75	50
UBD A140 xxAG	114	140	162	180	198			•							
UBD A140 xxBG	114	140	162	180	198				•						
UBD A210 xxEG	171	210	243	271	296		•						•	100	70
UBD A210 xxAG	171	210	243	271	296			•							
UBD A210 xxBG	171	210	243	271	296				•						

\*UBD A035xxEG has 1/4" male thread.

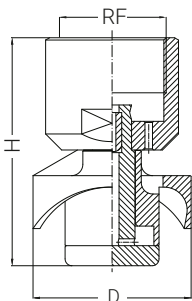

UBD A140

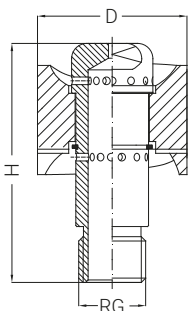

UBD A035

# UBD S

Reaction drive mono-axial head UBD S035 B31EG is totally realized in AISI 316L stainless steel. Moreover, no lubrication is needed, therefore there is no risk of contamination with oils: this product is suitable in applications in food, pharmaceutical and chemical industries. It has a low capacity and low angular velocity, so it is perfect for washing small and medium size tanks that require longer washing cycles. The easy and strong design, and high quality structure assure a long service and a high efficiency.



MATERIAL: B31 AISI 316L STAINLESS STEEL

CONNECTION: BSP FEMALE G 3/8, NPT, CLIP-ON FOR PIPES Ø18 EN 10357 B SERIES, CLIP-ON FOR PIPES Ø19 EN 10357 A SERIES



Washing liquid for ATEX products  
T ≤ 90°C P ≤ 10 bar



CODE	Capacity at different pressures						l/min bar
	2,0	3,0	5,0	7,0	10	12	
UBD S013 B31Ex CA	11	13	17	20	24	26	
UBD S018 B31Ex CA	15	18	23,3	27,5	33	36	
UBD S040 B31Ex CA	33	40	51,6	61	73	80	
UBD S054 B31Ex CA	44	54	70	82	99	108	

CA at the end of the code is used to differentiate a MOCA certified product from a non-certified one.

The x must be replaced by the required connection: G (3/8" F BSP), N (3/8" F NPT), C (clip connection for pipes Ø18 EN 10357 B series), D (clip connection for pipes Ø19 EN 10357 A series). We recommend using at least 100 mesh filter. The flow rate refers to the threaded model.

# UB3 S

The UB3 S rotating tank cleaning nozzle is a 3-A 78-04 certified cleaning device, compliant with U.S. regulations governing the design and manufacturing of equipment intended for food contact. UB3 S nozzles feature low-speed rotation and are made of stainless steel AISI 316L EN 1.4404. The nozzle is suitable for use with products commonly employed in CIP processes and compatible with AISI 316L stainless steel. However, it must not be used with fluids or substances that could be aggressive toward AISI 316L stainless steel. The primary application of the UB3 S is cleaning small to medium-sized tanks in the pharmaceutical, chemical, and food industries. This intended use and compliance with 3-A standards results in two key features of the UB3 S: easy assembly and disassembly and self-cleaning of internal components (for which the head must be installed vertically, because horizontal installation does not guarantee complete emptying of the device).

MATERIAL: B31 AISI 316L STAINLESS STEEL  
CONNECTION: CLIP-ON FOR PIPES Ø19 (DIN 11866 RANGE A)

Washing liquid for ATEX products  
T ≤ 90°C

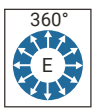

Clip connection

CODE	Flow rate l/min @3 bar	H	H1	ØDe	ØOD	ØID
UB3 S023 B31EC	23	106	22	30	24	19,3

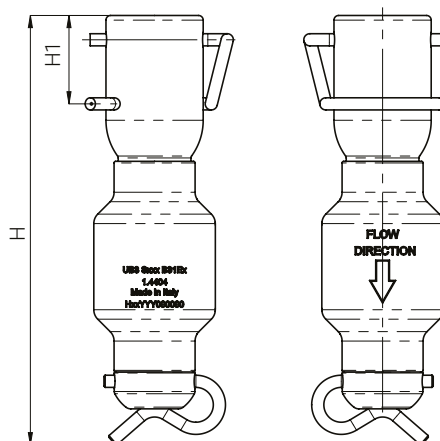
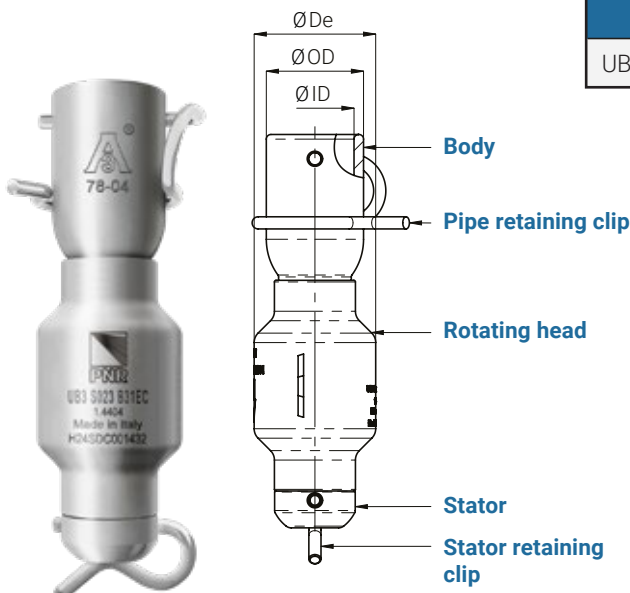

# UBX

UBX is a very compact product whose design provides for a specially accurate cleaning of the upper area of the tank around the inlet pipe, which is accomplished by a larger rotating head and straight jets with a well studied and appropriate orientation. Because of the low flow values, the simple design and the high quality surface finish UBX tankwashers are preferred in such application as washing small volume tanks in pharmaceutical processes.

The rotation is obtained by liquid reaction forces, while the head rotates over a thin liquid film which is self-cleaning. Connection can be threaded or with standard PNR clip for easy disassembly and cleaning.

MATERIALI: BODY B31 AISI 316L STAINLESS STEEL  
 ROTOR E1 PTFE  
 E13 PTFE + CARBON  
 D9 PEEK (ON REQUEST)

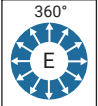
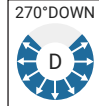
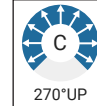

Thread connection

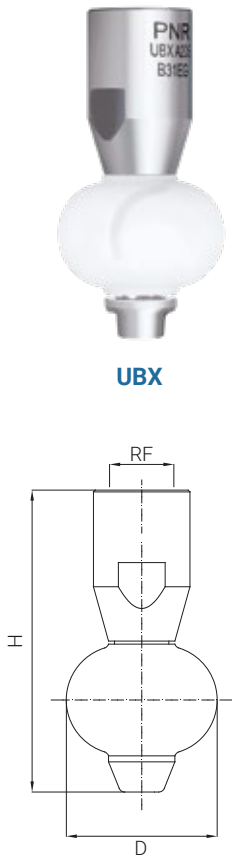

CODE	Capacity at different pressures					Spray coverage deg			RF BSP				Dimensions mm		
	2,0	3,0	4,0	5,0	6,0	360	270u	270d	1/4"	3/8"	1/2"	3/4"	H	D	
UBX A10S B31EG	8,20	10,0	11,6	12,9	14,1	.			.				50	25	
UBX A10A B31DG	8,20	10,0	11,6	12,9	14,1		.		.						
UBX A15S B31EG	12,2	15,0	17,3	19,4	21,2	.			.						
UBX A20C B31CG	16,3	20,0	23,1	25,8	28,3		.		.						
UBX A20S B31EG	16,3	20,0	23,1	25,8	28,3	.			.						
UBX A20S B31CG	16,3	20,0	23,1	25,8	28,3		.		.						
UBX A20S B31 DG	16,3	20,0	23,1	25,8	28,3			.	.						
UBX A30A B31EG	24,5	30,0	34,6	38,7	42,4	.			.			60	30		
UBX A30A B31DG	24,5	30,0	34,6	38,7	42,4		.		.						
UBX A30S B31EG	24,5	30,0	34,6	38,7	42,4	.			.						
UBX A30S B31CG	24,5	30,0	34,6	38,7	42,4		.		.						
UBX A30S B31DG	24,5	30,0	34,6	38,7	42,4			.	.						
UBX A40A B31EG	32,7	40,0	46,2	51,6	56,6	.			.			75	40		
UBX A40S B31EG	32,7	40,0	46,2	51,6	56,6	.			.						
UBX A40S B31CG	32,7	40,0	46,2	51,6	56,6		.		.						
UBX A40S B31DG	32,7	40,0	46,2	51,6	56,6			.	.						
UBX A50S B31EG	40,8	50,0	57,7	64,5	70,7	.			.			100	50		
UBX A70A B31EG	57,1	70,0	80,8	90,4	99,0	.			.						
UBX A70S B31EG	57,1	70,0	80,8	90,4	99,0	.			.						
UBX A70A B31CG	57,1	70,0	80,8	90,4	99,0		.		.						
UBX A70A B31DG	57,1	70,0	80,8	90,4	99,0			.	.						



PNR Italia is introducing on the market its classic products made of **MDT material** (*magnetically detectable thermoplastics*) and specifically **PPh** (*polypropylene homopolymer*).

MDT compounds are created to be detected by any type of detector, even when present in very small parts, making them suitable for metal replacement. MDT compounds are traceable by all metal detectors on the market (both fixed magnet and balanced coil ones), unlike compounds loaded with ferromagnetic powders. Furthermore, the MDT compounds do not use steel fibers or metal powders, and they do not contain carbon, graphite or carbon black fibers. Thanks to these characteristics, components manufactured with MDT do not release, in operation, powders or particles that are difficult to confine and therefore capable of dispersing in the working atmosphere and remotely contaminating the process or finished products.

MDT products are suitable for contact with food, and are produced in dark blue color in order to be better identified in any circumstance.

# UBF SMALL DIMENSION WASHING HEADS

UBF range heads have been designed as small dimensions devices to be operated through small dimension openings and perform such processes as the inside cleaning of any other container where standard washing heads cannot be used. Typically used for cleaning beer kegs, containers for soft drinks or small bore pipes. Also available with NPT connection.

MATERIAL: B31 AISI 316L STAINLESS STEEL + BEARINGS PTFE  
L61 ALLOY C22

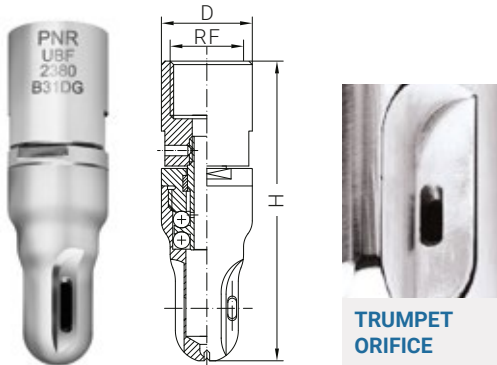

TRUMPET ORIFICE

**EXCLUSIVE TRUMPET ORIFICE**  
The new trumpet design of the side orifices allows to obtain a more efficient fan shaped jet, with a well defined spray angle, improving considerably the washing action.

Washing liquid for ATEX products  
T ≤ 90°C  
P ≤ 10 bar

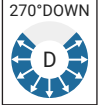
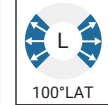

BSP or NPT threaded connection

CODE	RF BSP	Capacity at different pressures					Spray coverage deg		Dimensions mm	
		2,0	3,0	5,0	10	12	100L	270d	H	D
UBF 2270 B31 LG	1/2"	20,0	27,0	36,4	51,5	56,4	•		85	26
UBF 2270 B31DG		22,0	27,0	36,4	51,5	56,4		•		
UBF 2380 B31DG		31,0	38,0	49,2	69,3	76,0		•		

In case of NPT thread the last letter of the code will be N instead of G. The version in L61 differs from that in B31 only for the material of realization while the performances, the dimensions and the modalities of connection remain the same.

## UBF A

Designed for cleaning processes in small bore piping or small size containers and available in a range of different plastic materials and special alloys, as well as with several spray angles. Also available with NPT connection.

MATERIAL: D82 PVDF (MOLDED)  
B31 AISI 316L STAINLESS STEEL + BEARINGS PTFE  
E1 PTFE (FDA APPROVED)  
L61 ALLOY C22 + BEARINGS PTFE

Washing liquid for ATEX products  
T ≤ 90°C



only for: AISI 316L Alloy C22

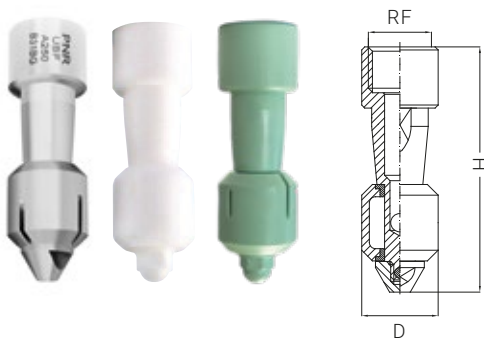
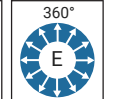
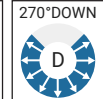
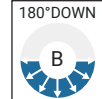

BSP or NPT threaded connection

CODE	RF BSP	Capacity at diff. pressures			Spray coverage deg			Dimensions mm	
		2,0	3,0	4,0	180d	270d	360	H	D
UBF A250 xxBG	1/2"	20,0	25,0	28,8	•			80	25
UBF A250 xxDG		20,0	25,0	28,8		•			
UBF A250 xxEG		20,0	25,0	28,8			•		

In case of NPT thread the last letter of the code will be N instead of G. The version in L61 differs from that in B31 only for the material of realization while the performances, the dimensions and the modalities of connection remain the same.

## UBF S

Designed for cleaning processes in very small bore piping or containers, down to 13 mm diameter. The device is available in different materials as well as spray angles, and with NPT connection

MATERIAL: B31 AISI 316L STAINLESS STEEL  
L61 ALLOY C22  
E1 PTFE (FDA APPROVED)



only for: AISI 316L Alloy C22

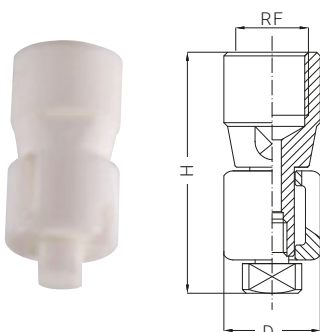
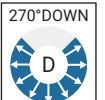

CODE	RF BSP	Capacity at diff. pressures			Spray coverage deg	Dimensions mm	
		2,0	3,0	4,0	270d	H	D
UBF S055 xxDG	1/8"	4,50	5,50	6,40	•	32	13

# UBA

UBA series heads operate producing water jets out of a spray head rotating around a vertical axis, but feature a sophisticated design where the head is put in slow motion by a simple friction transmission. As the motor produces a low rotation velocity, the jets can work with their maximum efficiency since not being broken into droplets: this makes it possible to obtain a higher impact force onto the tank wall. The head design can include one jet directed upwards which is meant to clean the tank roof area around the feed pipe, a difficult area in many instances, realizing then a true 360° spray pattern.

Superior cleaning power, faster cleaning cycles and lower volumes of cleaning solution required. UBA washing heads are available in two sizes, and three different jet patterns, as shown below. Rotation speed varies, depending upon feed pressures, between 5 and 12 rpm. Thread connection are available both in BSP standard (last letter of the code: G) and NPT standard (last letter of the code: N).

MATERIAL:	BODY, SPHERE	B31	AISI 316L STAINLESS STEEL
		L61	ALLOY C22
		E1	PTFE (ONLY MODEL 3150)
	BUSHINGS	E1	PTFE
	MOTOR RING	E1	PTFE

Washing liquid for ATEX products  
T ≤ 90°C

**Ex** only for: AISI 316L Alloy C22

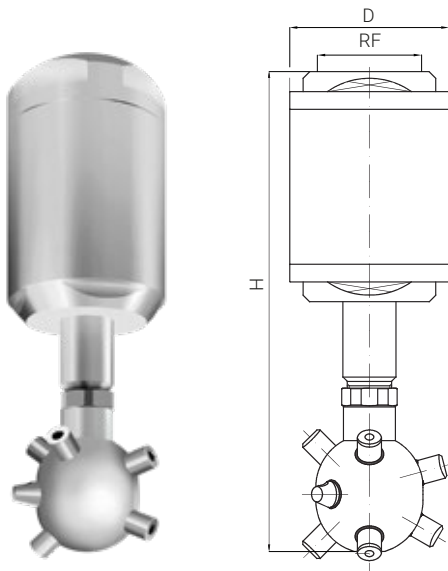
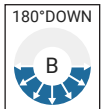
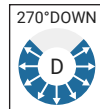
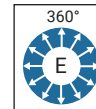

UBA 3150

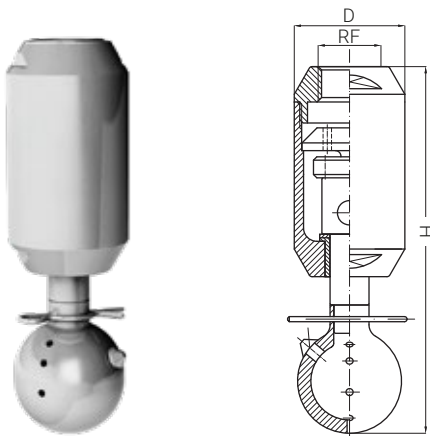

UBA 2500

CODE	RF BSP	Capacity at different pressures				Spray coverage deg			Dimensions mm	
		3,0	5,0	7,0	10	180d	270d	360	H	D
UBA 2500 B31BG	3/4"	50,0	64,5	76,3	91,3	.			166	50
UBA 2500 B31DG		50,0	64,5	76,3	91,3		.			
UBA 2500 B31EG		50,0	64,5	76,3	91,3			.		
UBA 3150 B31EG	1-1/2"	110	142	168	200			.	216	71

The UBA washing head is designed to accommodate in its sphere a wide variety of nozzles, both in number and type of spray (i.e., dart jet, blade, etc.). Each of these customizations involves, compared to the versions in the table, a variation also consistent with the performance, which will be provided from case to case.

In case of NPT thread the last letter of the code will be N instead of G. The version in L61 differs from that in B31 only for the material of realization while the performances, the dimensions and the modalities of connection remain the same.



# TWIN AXIS HEADS

## TWIN AXIS HEADS

The most sophisticated tank washing equipment, where high impact fluid jets slowly move with a combined rotation around one vertical and one horizontal axis. The motive mechanism assures the jet to hit always different paths at each turn, so that each single point of the inner tank surface is surely cleaned.

## TURBINE DRIVE

Sophisticated products offering modern design, excellent performance and high surface quality, mainly suitable for the chemical and pharmaceutical industry as they fully satisfy their demand for safe and reliable operation as well as perfect cleaning and sanitation.



# UBT

The UBT series tank wash heads are very sophisticated devices, designed with a robust structure and constructed with the latest technology to allow for high performance and providing excellent disinfection after each wash cycle. These characteristics are ideal for the automatic cleaning of industrial tanks and vessels. The nozzle movement is operated through an internal epicyclical gear reducer which enables to drive the jet paths according to a preset grid over the tank surface, providing a perfect cleaning of every single area inside the tank. Each side hub is equipped with two nozzles.

Depending on the application, two different types of nozzle can be used:

- Short nozzle: length 20 mm (Model C)
- Long nozzle: length 50 mm (Model L)

Each side hub is equipped with two nozzles whose orifice diameter determines the total water flow rate.

MATERIAL: METAL PARTS AISI 316L STAINLESS STEEL  
 SEALS CPTFE TEFLON + GRAFITE  
 OTHER MINOR PARTS PEEK

Washing liquid for ATEX products  
 T ≤ 90°C

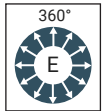

BSP, BSPT or NPT threaded connection

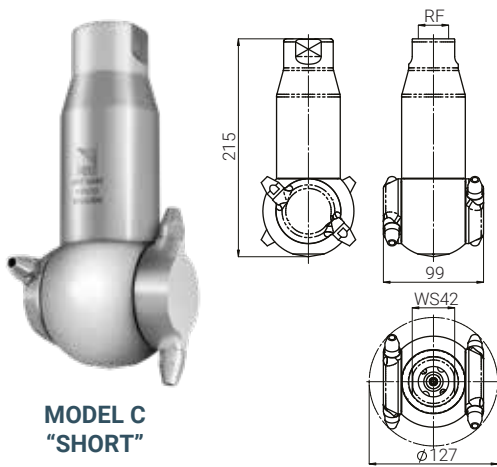

MODEL C "SHORT"

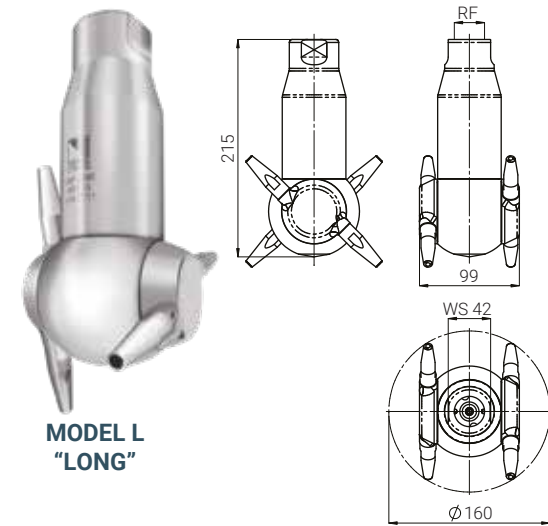

MODEL L "LONG"

CODE	Ø mm	RF BSPP	Capacity at different pressures						l/min bar	Weight Kg
			4,0	5,0	6,0	7,0	8,0	9,0		
UBT S445 B31CG	6,0	1"	88	92	100	108	115	121	130	3,6
UBT S445 B31LG			88	92	100	108	115	121	130	
UBT S460 B31CG			115	120	130	138	150	158	162	
UBT S460 B31LG			115	120	130	138	150	158	162	

To order the required product, please note that:

- second to last letter "C" indicates the Model C (short nozzle);
- second to last letter "L" indicates the Model L (long nozzle).
- Ø is the nozzle diameter.

In case of NPT thread the letter "G" will be replaced by "N", while in case of BSPT thread the letter will be "B".

If you want the version with sealed reducer, please contact our Sales Office for more information on Atex features.

In order to avoid problems with the device (such as breaking), the device must be used with carefully filtered water using a filter of at least 60 mesh, such as the VEM 0100 V1 filter (see next page for further information).



WETTING RADIUS UBT S445

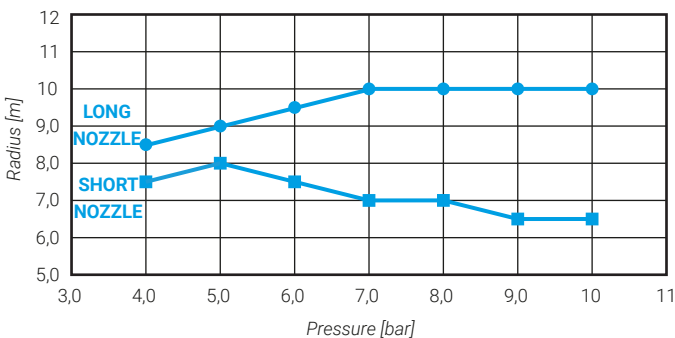

WETTING RADIUS UBT S460

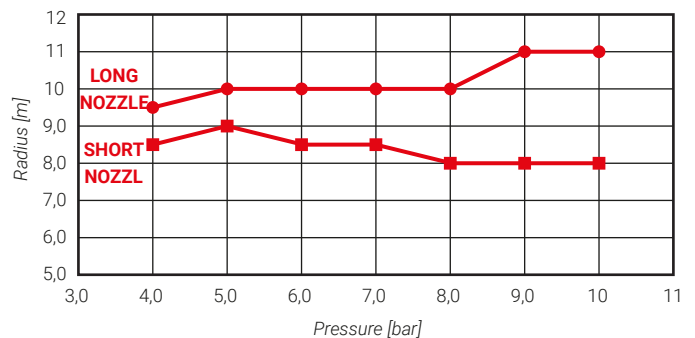

# VEM

VEM filters have been designed for high efficiency and ease of maintenance under hard conditions. The bowl houses large size cartridges, to extend periods of operation and reduce maintenance time, and has a thread connection to the body for quick removal without the aid of tools. Finally, a plug at the bottom of the bowl allows for fitting a ball valve to bleed the filter.

MATERIAL:	BODY	V1	ALUMINIUM CASTING
	BOWL	V1	ALUMINIUM CASTING
	CARTRIDGE	B2	AISI 304 STAINLESS STEEL
	CAP	A8	ZINC-COATED STEEL
	SEAL	E0	EPDM

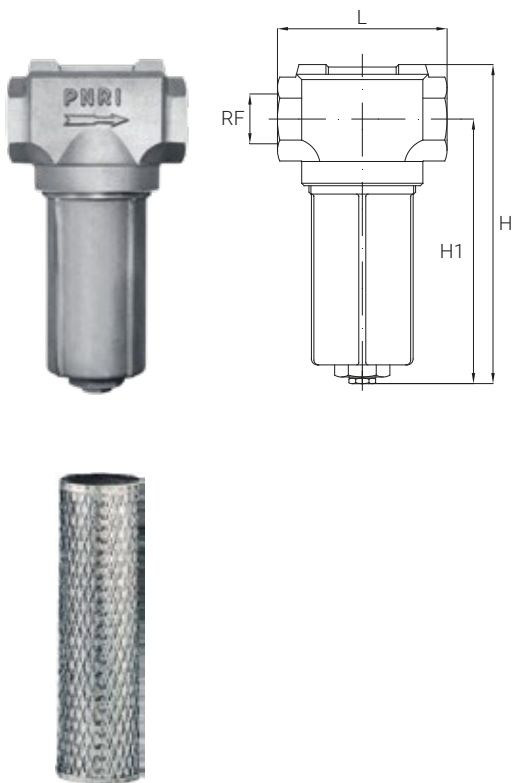

CODE	RF inch BSP	H mm	H1 mm	L mm	LP bar	Q l/min	Cartridge	M mesh	W kg
VEM 0050 V1 VEM 0051 V1	1/2"	210	165	119	40	70	XVE M075 B2 XVE M076 B2	60 80	0,9
VEM 0075 V1 VEM 0076 V1	3/4"	210	165	119	40	95	XVE M075 B2 XVE M076 B2	60 80	
VEM 0100 V1 VEM 0101 V1	1"	210	165	105	40	140	XVE M075 B2 XVE M076 B2	60 80	
VEM 0125 V1 VEM 0126 V1	1-1/4"	261	216	140	30	280	XVE M150 B2 XVE M151 B2	60 80	1,6
VEM 0150 V1 VEM 0151 V1	1-1/2"	278	233	140	30	315	XVE M150 B2 XVE M151 B2	60 80	
VEM 0200 V1 VEM 0201 V1 VEM 0202 V1	2"	400	326	200	10	750	XVE M300 B2 XVE M301 B2 XVE M302 B2	30 60 80	5,6
VEM 0250 V1 VEM 0251 V1 VEM 0252 V1	2-1/2"	400	326	200	10	810	XVE M300 B2 XVE M301 B2 XVE M302 B2	30 60 80	
VEM 0300 V1 VEM 0301 V1 VEM 0302 V1	3"	408	334	200	10	1050	XVE M300 B2 XVE M301 B2 XVE M302 B2	30 60 80	

## FILTER CARTRIDGE

In the table, you find the code of the cartridges available for every filter. The column "M" near the cartridge code show the value of filtration, in number of mesh.

MESH number	Free passage mm
30	0,60
60	0,25
80	0,18
100	0,15



# UMV

The UMV series washgun has been designed primarily to avoid hot water waste, while assuring very comfortable operation conditions. Its thick rubber casing not only effectively protects the operator's hand from the discomfort of hot water but also assures an excellent protection in case the washgun is dropped or falls to the ground since it avoids any damage to the tiles or the equipment. The careful design, mainly used for the food industry, also includes a grease and detergent resistant quality rubber, plus a blue colour has been chosen as a visual aid to be seen clearly against a white or clear foreground. The trigger is lined too, and can be held in the open position by means of a lock-ring. The spray pattern can be adjusted continuously between a closed straight jet to a wide angle spray, so that the proper spray pattern can be chosen for each individual job.

**MATERIAL:**

BODY	T2 BRASS CASTING, CHROME PLATED
	B31 AISI 316L STAINLESS STEEL
LINING	E0 EPDM
STEAM	B3 AISI 316 STAINLESS STEEL
TRIGGER	B3 AISI 316 STAINLESS STEEL, RUBBER LINED

**PERFORMANCE:**

Q	21 LPM @ 3 BAR UMV 2210
	61 LPM @ 3 BAR UMV 2211

**TECHNICAL DATA:**

HOSE SHANK	13 MM	LT: 95° C LP: 24 BAR
WEIGHT	0.9 KG	

**COMPLETE GUNS CODE**

UMV 2210 xx	Standard, adjustable jet
UMV 220A xx	With foam lance
UMV 220B xx	With 1/4" female outlet, bare lance
UMV 220C xx	With 1/4" female outlet, heat protected lance

**SINGLE COMPONENTS CODE**

UMV 2211 xx	With 1/2" male quick thread, without lance
XUM V001 B2	Foam lance
XUM V002 B1	Quick connect coupling for foam lance, 1/2" F
XUM V003 B2	Universal lance, 1/4" F out, heat protection
XUM V004 B2	Universal lance, 1/4" F out, zinc-plated steel
XUM V005 xx	Nipple, 1/4" F x 1/2" F

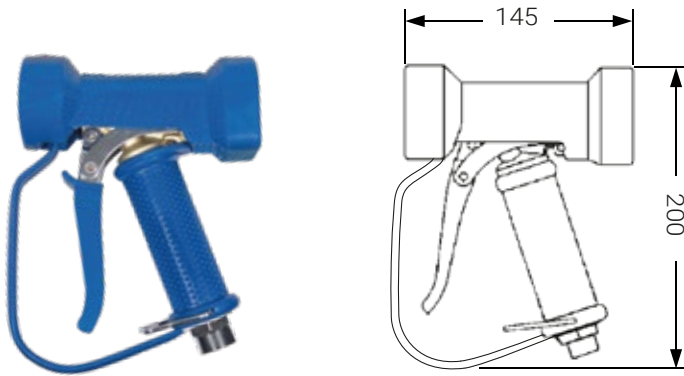

**UMV 2210 xx**

The versatility of this washgun is enhanced from the additional model UMV 2211 xx, which can be fitted with nozzles or different lances through its 1/2" male thread. The three different lance models shown are easily fitted to the gun body with a 1/2" male nipple and offer the following choices of operation:

- Foaming machines and equipment prior to washing operations. The foam lance comes with a quick connect female coupling, and a matching coupling must be fitted at the gun outlet.
- General purpose 1/4" female thread outlet, 1/4" male thread inlet. Available both with heat protection sleeve, or zincplated steel. The general purpose lance needs a connection nipple 1/4" fem to 1/2" female to be fitted on the gun.

**MATERIAL:**

**UMV 2210, UMV 2211, UMV 220A, UMV 220B, UMV 220C**

B31	AISI 316L STAINLESS STEEL
T2	CHROME-PLATED BRASS

**XUM V005**

B31	AISI 316L STAINLESS STEEL
T8	NICHEL-PLATED BRASS

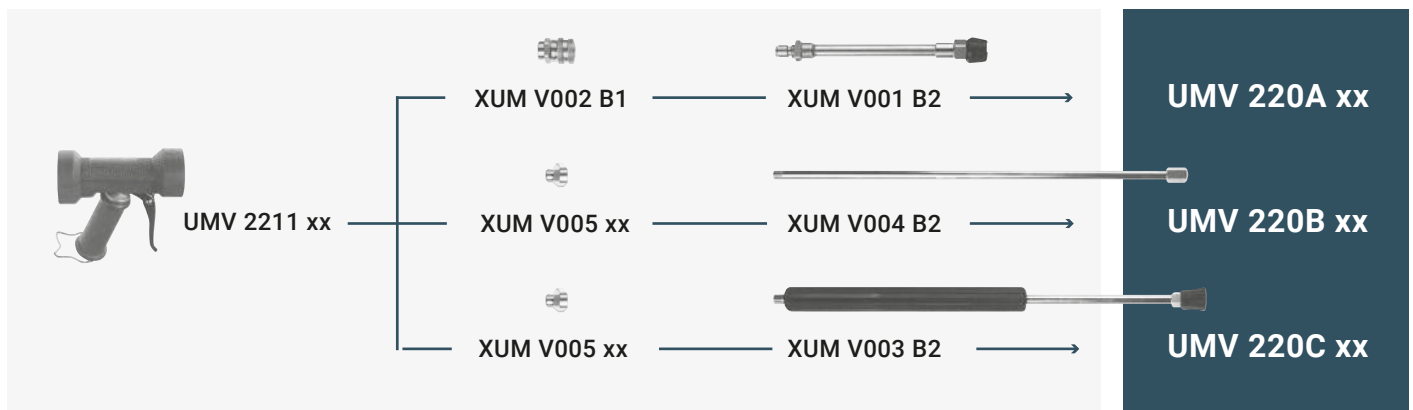

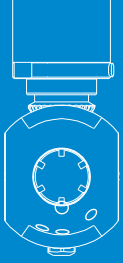

# HIGH-PRESSURE DEVICES

Thanks to the high impact force of the jets, the high-pressure spray balls use on average less liquid for cleaning than the lower pressures tank washing heads, with substantial long-term savings.

The advantages of using high-pressure washing heads are environmental – thanks to reduced water consumption – and, consequently, economic. The disposal of spent cleaning liquids represents an expensive activity in company budgets. The high-pressure washing heads allow a substantial reduction of this asset, thanks to the reduced water consumption.

On the other hand, high-pressure cleaning devices require greater energy expenditure for their correct operation and, therefore, highly performing systems.

The main applications of high-pressure washing heads are cleaning small-medium size tanks and open or closed containers of limited size characterized by persistent dirt.



## REDUCED WATER CONSUMPTION

Thanks to the high impact force of the jets, the high-pressure spray balls use on average less liquid for cleaning than the lower pressures tank washing heads.

## APPLICATIONS

The main applications of high-pressure washing devices are cleaning small-medium size tanks and open or closed containers of limited size characterized by persistent dirt.

## ECONOMIC SAVING

The disposal of spent cleaning liquids represents an expensive activity in company budgets. The high-pressure washing heads allow a substantial reduction of this asset, thanks to the reduced water consumption.

## UBR

The washing devices of the UBR series have been designed to wash small containers with an effective high-pressure straight jet. This product is driven by an external electric or pneumatic motor, allowing only the tube with the rotating head to be introduced into the container to be washed. This configuration ensures high reliability, and the limited dimensions allow for easy transport. The highest quality materials, high precision mechanical machining, and the choice of motors produced by selected suppliers make these devices ideal in many applications. These washing devices can be introduced into the tanks with three different solutions:

- *conical caps* for temporary use on openings of various diameters;
- *tri-clamp or swivel joints* for removable mounting;
- *connections with flange* for stationary mounting.

The Cleaning Device is provided with a *Declaration of Conformity* to the essential safety requirements according to 2006/42/CE. We also provide *IP65 protection grade for electrical parts*.

MATERIAL: BODY+COMPONENTS  
GASKET  
O-RING

B31 AISI 316 STAINLESS STEEL, PA12  
PTFE + CARBON FIBER  
VITON

LT: 90° C  
LP: 150 bar

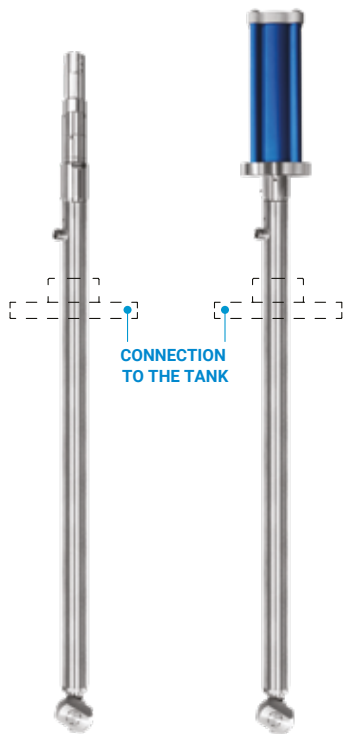
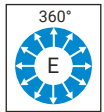

PNEUMATIC MOTOR

ELECTRIC MOTOR

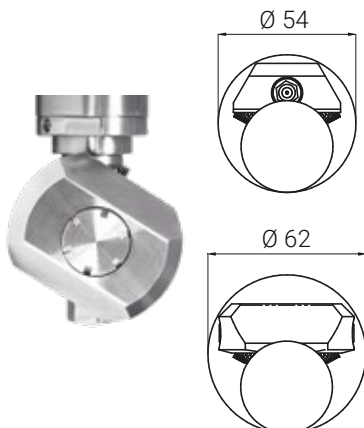

CODE **	FLOW RATE VARIANT	FLOW RATE [l/min] at 10 bar	FLOW RATE [l/min] at 15 bar	FLOW RATE [l/min] at 20 bar	FLOW RATE [l/min] at 35 bar	FLOW RATE [l/min] at 50 bar	FLOW RATE [l/min] at 100 bar	FLOW RATE [l/min] at 150 bar
UBR C (pneumatic motor)	008	4,22	5,17	5,97	7,90	9,44	13,4	16,4
	011	5,83	7,14	8,24	10,9	13,0	18,4	22,5
	016	8,66	10,6	12,2	16,2	19,4	27,4	33,6
UBR D (electric motor)	020	10,6	13,0	15,0	19,9	23,8	33,7	41,3
	026	13,8	16,9	19,5	25,8	30,8 *	43,6 *	53,4 *
	031	16,4	20,1	23,2	30,7	36,7 *	51,9 *	-
	037	19,8	24,2	27,9	36,9	44,1 *	-	-

\* Indicative values

\*\* To be defined tube length + connection (for more information, see the data sheet on our website [www.pnr.eu](http://www.pnr.eu))

MOTORIZATIONS	PNEUMATIC (C) AND ELECTRIC (D)
TUBE LENGTH* AND WEIGHT PNEUMATIC VERSION	500 mm > 4.2 Kg 700 mm > 5.1 Kg 1000 mm > 6.5 Kg 1500 mm > 8.7 Kg 2000 mm > 11 Kg
TUBE LENGTH* AND WEIGHT ELECTRIC VERSION	500 mm > 6.3 Kg 700 mm > 7.3 Kg 1000 mm > 8.6 Kg 1500 mm > 11 Kg 2000 mm > 13.2 Kg
WORKING PRESSURE	from 35 to 150 bar
FLOW RATE	from 8 to 37 l/min @ 35 bar from 17 to 76 l/min @ 150 bar
OPERATING TEMPERATURE	80°C Max
NOZZLES NUMBER	2
WATER CONNECTION	3/8" BSPP
MINIMUM OPENING FOR INSTALLATION	Ø > 62 mm

\* Possibility of requesting the tube length from a minimum of 500mm

# ROTOSH

The Rotosh washing device complies with the CE Directive and can simultaneously wash and aspirate barriques and tonneaux.

Made of stainless steel, Rotosh consists of a 12V DC gear motor, beneath which is a lever for selecting the working mode: either washing and suction or suction only.

The device includes a rubber pad to place at the barrel entrance, washing nozzles, and a hose with a suction nozzle that operates via a hydraulic ejector. The hose also has an extension to wash tonneaux.

A complete washing cycle lasts 37 seconds, but a double cycle is recommended for optimal cleaning. The nominal operating pressure is 120 bar, and the flow rate is 25 l/min. The device is supplied with three nozzle kits, adaptable to different customer pumps. The device is powered by a 12V transformer (included) connected to mains voltage.

MATERIALS: STAINLESS STEEL

WATER INLET: G 3/8 F

WATER OUTLET: Ø 17 mm

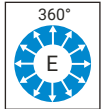

TECHNICAL DATA	
RATED PRESSURE	120 bar
MAX WORKING PRESSURE	140 bar
RATED FLOW RATE	25 l/min
RATED TEMPERATURE	80 °C
COMPLETE WASHING CYCLE	37" (double cycle recommended)
ELECTRIC MOTOR	12 V DC
POWER SUPPLY	230V (50Hz) 115V (60Hz)
POWER	IP 55
LENGHT OF CABLE WITH WATERPROOF CONNECTIONS	10 m
NOZZLES ROD ROTATING SPEED	52 rpm
MINIMUM TANK INLET DIAMETER	40 mm
WEIGHT	4,8 kg

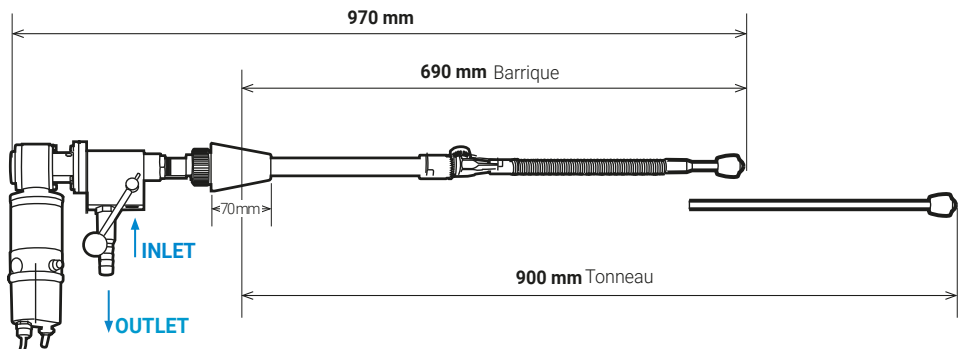

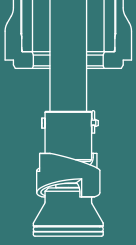

# SPECIAL PRODUCTS

In addition to the traditional heads, which fixed position to the surface to wash, PNR offers a range of products with a mobile position for the cover. The mobility of the washing head for this category can be determined by the reaction force of the washing fluid itself (for example, the UC) or by the energy supplied by an actuator, be it hydraulic or pneumatic (UK).

The washing heads defined as exceptional executions divided into two categories:

## RETRACTABLE HEADS MOVED BY AN ACTUATOR

Used:

- when a fixed element in the tank can hinder the production process;
- when the process fluid does not come into contact with the washing fluid;
- when a fixed head position inside the tank does not guarantee washing uniformity over the entire surface.

## HEADS MOVED BY THE FORCE OF REACTION

of the same washing fluid, mainly used for washing pipes.



# UKD / UKR

Our new UK tank washer is a revolution in retractor design, as it offers at the same time greater efficiency, extreme flexibility and an easier operation capability.

We put aside the bulky stainless-steel construction and operate our washing head via a pneumatic drive or CNC. Hence the following advantages:

- the total impact of the water jet is concentrated on the circumference of one or two hollow cone sprays, moving into the tank instead of being inefficiently dispersed over the entire internal surface;
- the alternating movement of the washer covers the total inner surface of the tank and allows what was previously impossible, such as cleaning the opposite sides of an internal mixing blade;
- having control of cylinder movement, we can program short cycles concentrated over difficult points as many times as necessary; our standard double hollow cone head has a capacity of 100 lpm at 3 bar, but customized designs can be studied, according to customer requirements.

Of course, you can use our new UK retractor as a standard one, which is installing on it a rotating head from our UBD series. The minimum operating pressure of UKD cleaning device is 2 bar. Suggested filtration is about 80 mesh.

MATERIAL: AISI 316L S.S., EPDM, TEFLON/PEEK

CONNECTIONS: HEAD STRUCTURE FIXED WITH TRI-CLAMP CONNECTION  
SUPPORT STRUCTURE WELDED TO THE TANK



STROKE	A	B	C	D	E	F	Q	D1*	D2	D3	D4	WS	RG1	RG2	RG3
100 ÷ 500 STEP 50 mm	260	108	~60	~40	~120	50	75	65	42	~90	77,5 DIN 32676-C 2" 1/2 T.C	30	1/2"	3/8"	3/8"

\* This must be the hole of the tank. RG1: fluid inlet connection. RG2, RG3: air inlet connection to extend / retract

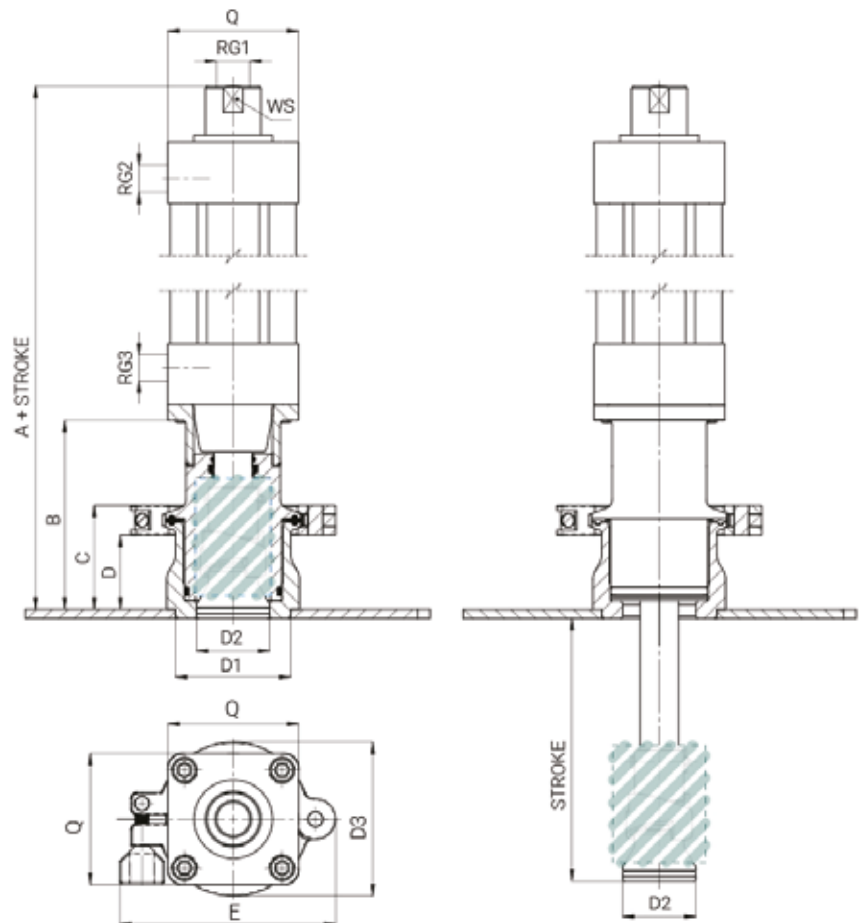

The pneumatic cylinder is equipped with special positioning sensors that generate digital signals when the washing vheads is either in fully extended or fully retracted positions.

# UKK / UKK A

UKK is a retractable tank washing head designed for cleaning small containers, tanks, and pipes. Thanks to its small size and unique design, UKK can be installed flush with the wall and is an ideal cleaning product where traditional systems have difficulty accessing and operating.

Its characteristics make UKK an ideal product in the chemical and pharmaceutical sectors, and the FCMs certification also allows it to be used in the food and beverage sector.

The operation of this cleaning head is simple but highly effective: with an adequate pressure of the feed liquid (between 3 and 7 bar), the nozzle extends by 50 mm and starts the washing action. The flow rate is 35.5 lpm at 3 bar of operation.

The **UKK A variant, thanks to introducing a new gasket**, cancels the possibility of water infiltration inside the head from the tank with a closed device.

UKK is available in AISI 316 steel as a standard material with the possibility of using other metallic materials such as Hastelloy.

MATERIAL:	BODY	B31	AISI 316L S.S. (HASTELLOY ON REQUEST)
	COMPONENTS	B31	AISI 316L S.S.
		E7	VITON (FKM) PEEK FDA

LT: 90° C

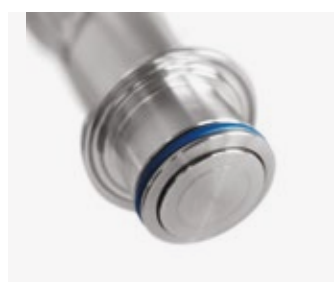

UKK A with Viton seal

<b>FLOW RATE</b>	from 15 to 60 l/min @ 3 bar
<b>TEMPERATURE MAX</b>	90°C
<b>BODY MATERIAL</b>	AISI 316L s.s.
<b>COMPONENTS MATERIAL</b>	AISI 316L s.s. VITON (FKM) - FFKM PEEK FDA
<b>PRESSURE RANGE</b>	3-7 bar
<b>CONNECTION</b>	Tri-clamp 1" 1/2
<b>COVERAGE</b>	320° up

CODE	PRESSURE (bar)	3	4	5	6	7
UKK 015D B31	FLOW RATE (lpm)	15	18	19	21	23
UKK 020D B31		20	24	27	30	32
UKK 035D B31		35	41	46	51	55
UKK 050D B31		50	60	66	73	78
UKK 060D B31		60	66	74	80	87

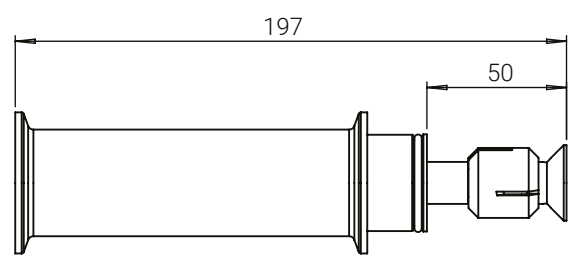

The UKK stroke is 50 mm. The overall length of the standard version is 197 mm.

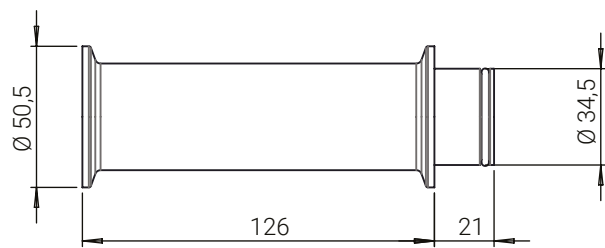

The overall diameter of the UKK is 50,5 mm. The distance between the tri-clamp connections is 126 mm.

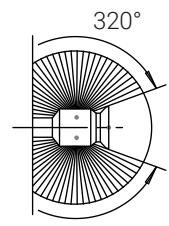

# UC

UC washing heads are products designed specifically for cleaning pipes. They are generally used with high pressures and exploit the reaction forces created by suitably oriented jets to create a forward push and facilitate cleaning.

These new washing heads, available with two different connection, are generally used with high pressures and exploit the reaction forces created by suitably oriented jets to create a forward push and facilitate cleaning. Therefore, you can clean pipes of different length using only this washing head, without any further installation, saving time and costs.

Different flow rates are available, depending on the connection and on the dimension of the holes of the head.

MATERIAL: AISI 303 STAINLESS STEEL, AISI 304 S.S., AISI 316L S.S., AISI 416 STAINLESS STEEL HARDENED, BRASS

CONNECTION: 1/8" BSPP, 1/4" BSPP

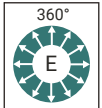

UCA



UCB

CODE	Capacity at different pressures						l/min bar	Ø holes mm
	3,0	10	30	70	90	100		
UCA 1900 zz	1,80	3,10	5,10	8,00	9,10	9,40	0,6	
UCA 2160 zz	3,30	5,70	9,40	14,1	15,9	16,7	0,8	
UCB 2285 zz	5,20	9,5	16,5	25,1	28,5	30,0	1,0	
UCB 2405 zz	7,45	13,6	23,6	36,0	40,7	43,0	1,2	

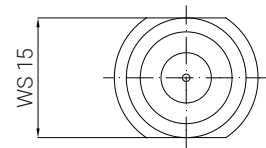
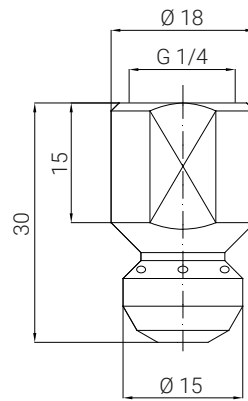
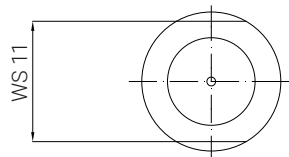
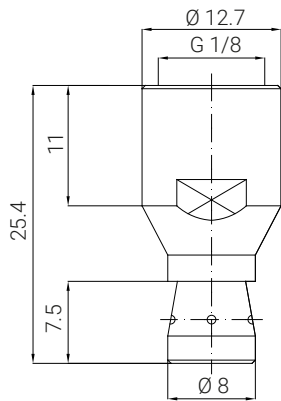

## APPLICATIONS OF SPECIAL PRODUCTS

Our sales technicians have complete knowledge of all the industrial applications of our products and a high degree of technical expertise to help you find the best solution for your needs, from planning the production process to improving and optimizing production plants.

We don't just supply products: we also provide integrated services and support. We are available to evaluate requests for products customized according to your specifications or for particular applications.

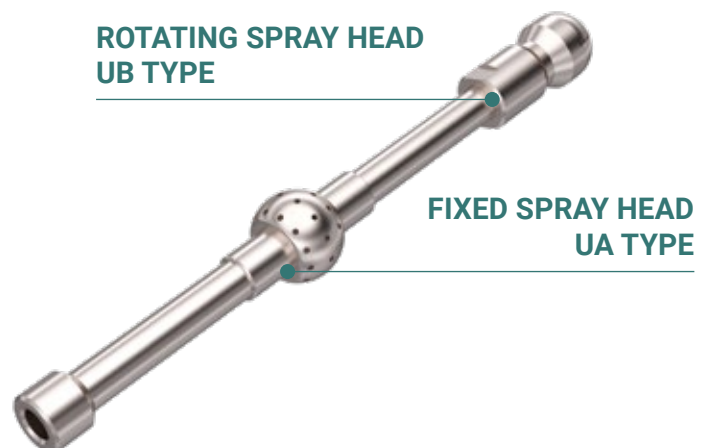

## SUMMARY TABLE

SERIES	CONNECTION	MATERIALS	FLOW RATE RANGE (lpm)	OPERATING PRESSURE (bar)	MAX WETTING RADIUS (m)	SPRAY COVERAGE (deg)
CH	threaded (3/4" ÷ 2")	303 s.s. 316L s.s. Ottone	8,26 ÷ 481 [3 bar]	1,0 / 10,0	3,0	360° DOWN 180°
UA3	clip-on	316L s.s.	2,6 ÷ 19,3 m³/h [1 bar]	1,0 / 2,5	3,5	360° UP 180° UP 270° DOWN 180°
UAB	threaded (1/2")	303 s.s. 316L s.s.	22 ÷ 145 [3 bar]	2,0 / 5,0	3,5	DOWN 240°
UAC	threaded (1/8" ÷ 1-1/4"), clip-on, welded	316L s.s. Hastelloy C267 Titanium Gr2	1,2 ÷ 49,1 m³/h [1 bar]	1,0 / 3,0	3,5	360° UP 180° UP 270° LAT 100° DOWN 270° DOWN 180°
UB3 A	clip-on for pipes Ø19	316L s.s. PEEK + 10% PTFE	40 ÷ 100 [3 bar]	1,0 / 3,0	3,0	360°
UB3 S	clip-on for pipes Ø19	316L s.s.	23 [3 bar]	2,0 / 4,0	3,0	360°
UBB	threaded (1/2" ÷ 3")	PTFE	30 ÷ 1380 [3 bar]	1,5 / 3,5	4,0	360° UP 180° UP 270° DOWN 270° DOWN 180°
UBC	threaded (3/8" ÷ 1-1/4"), clip-on, welded	316L s.s.	10 ÷ 300 [3 bar]	2,0 / 7,0	3,2	360° UP 180° UP 270° DOWN 270° DOWN 180°
UBD	threaded (1/4" ÷ 1-1/2")	316L s.s. Hastelloy C22	35 ÷ 210 [3 bar]	2,0 / 7,0	4,8	360° UP 180° DOWN 180°
UBD A	threaded (1/4" ÷ 1-1/2")	PTFE PEEK PTFE + 15% graphite	35 ÷ 210 [3 bar]	2,0 / 6,0	3,0	360° UP 180° DOWN 180°
UBD S	threaded (3/8")	316L s.s.	13 ÷ 54 [3 bar]	2,0 / 12,0	3,0	360°
UBF	threaded (1/2")	316L s.s. Hastelloy C22	22 ÷ 38 [3 bar]	2,0 / 12,0	1,5	100° LAT DOWN 270°
UBF A	threaded (1/2")	316L s.s. PVDF, PTFE Hastelloy C22	20 ÷ 25 [3 bar]	2,0 / 4,0	2,5	360° DOWN 270° DOWN 180°
UBF S	threaded (1/8")	316L s.s. PTFE	4,5 ÷ 5,5 [3 bar]	2,0 / 4,0	0,8	DOWN 270°
UBX	threaded (1/4" ÷ 3/4")	316L s.s. PTFE PEEK	10 ÷ 70 [3 bar]	2,0 / 6,0	3,5	360° UP 270° DOWN 270°
UKK	tri-clamp (1" 1/2)	316L s.s. VITON PEEK FDA	35,5 [3 bar]	3,0 / 7,0	2,5	320° UP
UBA	threaded (3/4" or 1-1/2")	316L s.s. PTFE	50 ÷ 110 [3 bar]	3,0 / 10,0	4,5	360° DOWN 270° DOWN 180°
UBT	threaded (1")	316L s.s.	88 ÷ 115 [4 bar]	4,0 / 10,0	11,0	360°
UBR	threaded (3/8")	316L s.s. PA12	7,9 ÷ 36,9 [35 bar]	10,0 / 50,0	2,0	360°

## THREADED CONNECTIONS

The threads available for the washing devices in the catalogue with the relevant reference standards are listed below.

<b>G</b>	<b>Gas</b>	<b>ISO 228-1:2003</b>
<b>N</b>	NPT	TSII TCON07:2006
<b>B</b>	BSPT	UNI EN 10226:2006

## CLIP CONNECTION SIZE

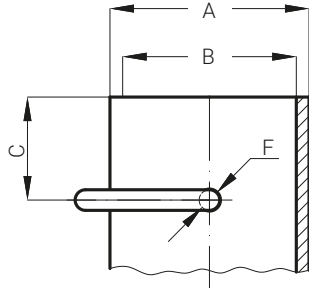

	A	B	C	F
<b>UBC <math>\phi</math> 25 (UBC xxxx MMxC)</b>	22,0	20,0	9,0	2,5
<b>UBC <math>\phi</math> 45 (UBC xxxx MMxC)</b>	29,0	25,3	15,0	3,2
<b>UBC <math>\phi</math> 65 (UBC xxxx MMxD)</b>	44,0	38,4	15,0	3,2
<b>UBD xxxx MMxC</b>	33,0	25,5	9,0	2,5
<b>UBD xxxx MMxD</b>	33,0	25,7	9,0	2,5

There is a number of different dimensions standards relating to clip-on connections on different markets, and between Europe and America. We have therefore identified with our Customers the most commonly requested types and have standardized as follows.

### UAC, FIXED SPRAY HEADS

Drawings and sizes are available at pages 5 and 6: these will be the future sizes for every PNR device with clip-on connection, and they are based on DN (nominal diameter), as defined by European standards.

### UBC AND UBD, REACTION DRIVE HEADS

For the two above product types clip-on connections will maintain specifications used until present time. The diagram and the table showing the dimensions for the two product types on the different markets is shown below, and covers both European pipe dimensions (last letter of the code: C) and American (last letter of the code: D).

The variety of applications of stainless steel pipes/tubes, welded or seamless, generated several Regulations related to diameters, thicknesses, methods of production and finishing, surface quality, acceptance criteria. Recently, the authorities in charge tried to simplify such regulatory vastness with Standard DIN 11866 dated June 2016 which we report here below for what concerns the dimensional part. The norm is divided into three Ranges:

- *Range A*: pipe dimensions according to DIN EN 10357 extended by DN6 and DN8 (includes also previous standard DIN 11850);
- *Range B*: pipe dimensions according to DIN EN ISO 1127 (includes also previous standards DIN 2642 for seamless pipes and DIN 2643 for welded pipes);
- *Range C*: pipe dimensions according to ASME-BPE 2009.

### NOTE

For the dimensioning of its tank washing heads, PNR adopts and uses DIN 11866:2016 as a reference standard, unless otherwise specifically requested by Customers. Standard DIN 11866:2016 does not include all previous Norms and measurement standards. Therefore, in this catalogue, it is possible to find references to dimensions of standards that are not included.

DIN 11866 Range A / 304L - 316L		
De (mm)	Thickness	DN
8,00	1,00	DN6
10,0	1,00	DN8
13,0	1,50	DN10
19,0	1,50	DN15
23,0	1,50	DN20
29,0	1,50	DN25
35,0	1,50	DN32
41,0	1,50	DN40
53,0	1,50	DN50
70,0	1,50	DN65
85,0	2,00	DN80

DIN 11866 Range B / 304L - 316L		
De (mm)	Thickness	DN
10,2	1,60	DN6
13,5	1,60	DN8
17,2	1,60	DN10
21,3	1,60	DN15
26,9	1,60	DN20
33,7	2,00	DN25
42,4	2,00	DN32
48,3	2,00	DN40
60,3	2,00	DN50
76,1	2,00	DN65
88,9	2,30	DN80

DIN 11866 Range C / 304L - 316L			
De (mm)	Thickness	DN	Rif.to
6,35	0,89	DN8	1/4"
9,53	0,89	DN10	3/8"
12,7	1,65	DN15	1/2"
19,05	1,65	DN20	3/4"
25,4	1,65	DN25	1"
38,1	1,65	DN40	1-1/2"
50,8	1,65	DN50	2"
63,5	1,65	DN65	2-1/2"
76,2	1,65	DN80	3"

## ABBREVIATIONS

<b>De</b>	EXTERNAL DIAMETER	mm	<b>DN</b>	DIAMETRO NOMINAL DIAMETER		<b>Q</b>	CAPACITY	l/min
<b>Di</b>	INNER DIAMETER	mm	<b>H, H1</b>	HEIGHT	mm	<b>RF</b>	CYLINDRICAL FEM BSP THREAD	poll
<b>Dia</b>	ORIFICE DIAMETER	mm	<b>L, L1</b>	WIDHT	mm	<b>RG</b>	CONICAL MALE BSPT THREAD	poll
			<b>LP</b>	MAX WORKING PRESSURE	bar	<b>W</b>	WEIGHT	kg
			<b>LT</b>	MAX WORKING TEMP.	°C	<b>WR</b>	WETTING RADIUS	m

### DISCLAIMER

Our products are manufactured with the best care and according to the latest developments of the technology available. However we cannot assure that every one of our products is perfectly fit for every specific application. The information in this catalogue is provided "as seen" and so we offer no warranty of any kind with respect to the subject matter or accuracy of the information contained herein. This publication may include technical inaccuracies or typographical errors and changes may be periodically made to the information herein without prior notice.

As a result of continuous product improvement our documentation is regularly updated: please visit our website [www.pnr.eu](http://www.pnr.eu) to be always updated.

### PRODUCT WARRANTY

PNR Italia products shall be replaced and/or repaired at PNR Italia's discretion free of charge if they are found to be genuinely non-compliant due to manufacturing or packaging defects or incorrect labelling. The conformity guarantee shall only apply if PNR Italia receives written notice of non-conformity from the customer within 30 days from the date of installation of the product or within one year from the date of shipment. The cost of repair or the cost of replacing the product with an identical or equivalent product shall be the entire responsibility of PNR Italia and the exclusive remedy of the purchaser for any breach of warranty and PNR Italia shall not be liable for any personal injury or loss resulting from product malfunction.

This warranty does not cover problems or damage resulting if our products are improperly stored, assembled, or installed, used for a purpose other than that for which they were intended, tampered with, or used in a manner inconsistent with the instructions for the product such as, but not limited to:

- Operation at pressures higher than those indicated in the performance table published in the catalogue or product data sheet,
- operation with or exposure to fluids containing abrasive particles that can cause erosive wear,
- operation with or exposure to fluids that cause chemical aggression on the nozzle's material of construction,
- mechanical damage to the orifices, nipple or nozzle body caused by improper handling or assembly.

In all of the above cases, the customer must accept a reduction in the product's lifecycle or performance inferior to that declared in the catalogue by PNR Italia. Warranty claims shall be addressed directly to PNR Italia by drawing up a precautionary report or complaint on the conformity defect detected, which must be forwarded by email to: [quality@pnr.it](mailto:quality@pnr.it).

#### RETURN PROCEDURE

PNR Italia verifies and ascertains that the product which is the subject of the claim is actually covered by the established warranty period and communicates this in writing to the customer;

The customer shall apply in writing to PNR Italia for authorisation to return the product;

PNR Italia authorises the customer in writing to return the product, which must be returned by the customer in its original packaging the product which is the subject of the complaint must be returned in a manner that PNR Italia will communicate to the customer in writing and the transport costs of the returned goods shall be borne entirely by PNR Italia.

PNR Italia may, at its discretion, use new, refurbished or used parts in good working order to repair the product.

No salesperson, agent or employee of PNR Italia is authorised to make any modification, extension or addition to this Guarantee.

PNR Italia guarantees the best spray quality and accuracy of flow values, with a tolerance of 10% on the flow rate and  $\pm 5^\circ$  on the spray angle. Specific cases with smaller tolerances can be considered on a case-by-case basis.

### CERTIFICATIONS

#### 3-A

PNR Italia srl is authorized to use the 3-A Symbol to the tank washing head code UA3 xxxx B31 xCx, conforming to 3-A Sanitary Standard 78-04 (Spray Cleaning Devices Intended to Remain In Place).



#### MOCA

Tank washing heads produced exclusively in AISI 316L s.s. and / or pure PTFE are available in MOCA version ("Materials and objects in contact with food"), in accordance with the Framework Regulation 1935/2004 and Regulation 2023/2006, which establish the criteria of traceability and processing of materials. The MOCA version is available on customer's request for the washing heads produced in AISI 316L s.s., pure PTFE or with both materials.



#### ATEX

Single-axis rotary spray balls UBA, UBC, UBD, UBF, UBF-A, UBF-S and UBT are available in ATEX ("Atmosphères explosibles") version, in conformity with European Community Directive 2014/34/EU that determine compliance with the essential safety requirements for equipment and protection systems intended for use in potentially explosive atmospheres. ATEX version is available, on request, for tank washing heads made of AISI 316L s.s. or Hastelloy C22.



# NOTE





PNR ITALIA HA CERTIFICATO  
IL SUO SISTEMA DI QUALITÀ CON DNV  
SECONDO LE NORME ISO 9001/2015

**COMPANY WITH  
QUALITY SYSTEM**

**CERTIFIED BY DNV GL**

**ISO 9001:2015**

# A GLOBAL PRESENCE ALL OVER THE WORLD.

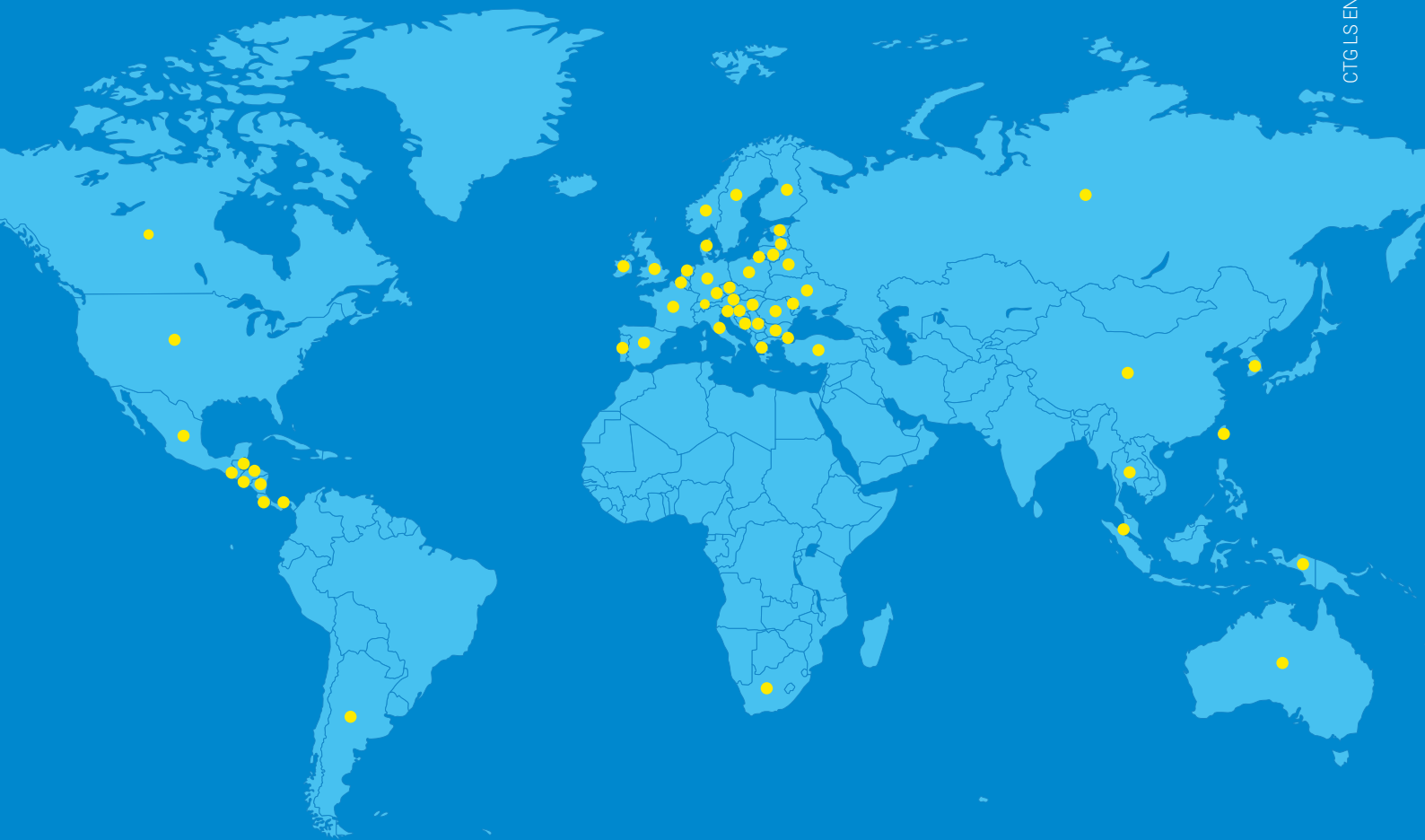

CTGLS EN - REV 25.03 - ©PNR Italia, all rights reserved



## **PNR ITALIA SRL - Socio Unico**

Via Gandini 2, 27058 Voghera (PV) Italy  
For more information, visit [www.pnr.eu](http://www.pnr.eu)

Call or write us for customized solutions!

☎ +39 0383 344 611    ✉ [info@pnr.it](mailto:info@pnr.it)

