

SCRAP TIRE SHREDDERS & RASPERS



- Integrated manufacturer of tire shredders and raspers
- Recognised clean-cut quality with extended knives life-time
- Highest energy & footprint efficiency (only one step to produce 50mm/2" chips)
- Mobile and stationary turnkey installations with enhanced monitoring
- Spare parts in stock & dedicated field service team
- Specialist of tire recycling for over 25 years

Company profile

Company start up : 1973 (over 40 years of market presence)

Location : Toulouse (France)

Specialized in manufacturing of scrap tyre SHREDDERS (rotary shears) & RASPERS

DNA : Technology driven & customers minded company

50 to 70 % export business

Sales : 5000 k€

Staff : 20 people

One Production site : 5000 m² (workshop : 2500 m²)

Banks : Société Générale/ Courtois/Caisse Epargne/Crédit Agricole

ASSETS (1/3):

Equipment specifically designed for scrap tires :

- Robust equipment for industrial use, to last for decades
- Excellent cut quality, very clean
- Extended life time of removable cutting knives
- Compliant with 2006/42 EC safety standards
- First class suppliers components
- Innovation based on customers needs

Shredder sizing & tires handling expertise :

- Guaranteed production capacity
- Mobile or stationary shredders
- Turn-key shredding installations
- Circa. 60 tires shredding installations worldwide

ASSETS (2/3):

Process expertise & understanding :

- Experience & seniority of staff with regular service visits on customers site

Market recognized reliable & « fit for purpose » equipment :

- High Overall Equipment Effectiveness (smooth trouble-free operation)
- Equipment often sold thanks to recommendations from existing customers (Referral Market)

Worldwide Proven track record : circa. 60 tires shredding installations

Fist class references : Veolia, Holcim, Cemex, Fives FCB, Lafarge, Vicat... & many local ones

ASSETS (3/3):

Integrated manufacturing :

- Mastering of design, engineering & manufacturing process
- Heavy duty, quality of manufacturing
- Revamping, refurbishing, retrofitting of used equipment
- Spare-parts (rotors, knives, etc..)

Passion, pride & flexibility of staff

Active member of European scrap tires committee for standardization (CEN TC 366)

- Co-founder of French scrap tires committee, extended to European level

Range of tyre shredders

	PC tyres pre-shredded	Truck tyres pre-shredder	PC tyres	Truck tyres	Agrarian tyres <1800 mm	OTR + Industrial Waste	Mobile model available	Rapid rotor exchange system	Type of knives	Average lifetime for each set of knives
RSP 500	X	X							removable, sharpenable knives	1200 t
RSP 1000	X	X							removable, sharpenable knives	1200 t
5-02-45	X		X						solid knives	1000 t
8-02-50	X	X	X				X	X	removable knives	2000 t
15-02-50	X	X	X	X			X	X	removable knives	2500 t
16-02-100	X	X	X	X	X		X	X	removable, sharpenable knives	4000 t
16-02-100 + 8-02-50	X	X	X	X	X			X	removable, sharpenable knives	NA
16-02-100 + 15-02-50	X	X	X	X	X			X	removable, sharpenable knives	NA
17-02-55	X	X	X	X	X	X		X	solid knives	1200 t

Range of tyre shredders

>150 mm	5-02-45			16-02-100			
100 mm				8-02-50			17-02-55
50 mm	8-02-50			16-02-100 + 8-02-50		15-02-50	
<25 mm	RSP 500	RSP 1000	2xRSP 500	2xRSP 1000	3xRSP 500	3xRSP 1000	4xRSP 1000
	1-2 tph	2-4 tph	4-6 tph	6-8 tph	8-10 tph	10-12 tph	>15 tph

PRECIMECA tyre shredders

5-02-45 mobile shredder to produce 50 mm chips from PC and 4x4 tyres :

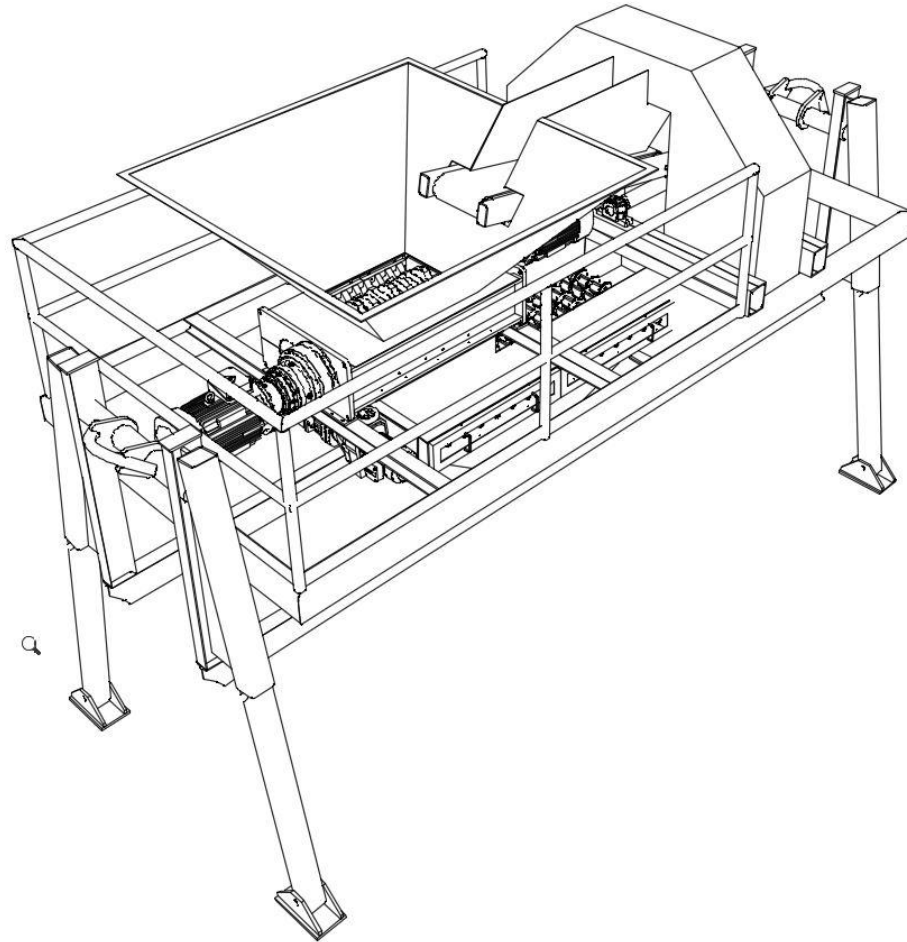

2 x 22 kW

PRECIMECA tyre shredders

**8-02-50 compact shredder to produce
50 mm chips from PC and 4x4 tyres :**



2 x 55 kW

PRECIMECA tyre shredders

**15-02-50 compact shredder to produce
50 mm chips from PC and truck tyres :**



2 x 110 kW

PRECIMECA tyre shredders

15-02-50 NEO shredder to produce 50 mm chips from PC and truck tyres :



2 x 125 kW

PRECIMECA tyre shredders

**15-02-50 mobile shredder to produce
50 mm chips from PC and truck tyres :**



2 x 110 kW

PRECIMECA tyre shredders

16-02-100 shredder to produce 100 mm chips from PC and truck tyres :

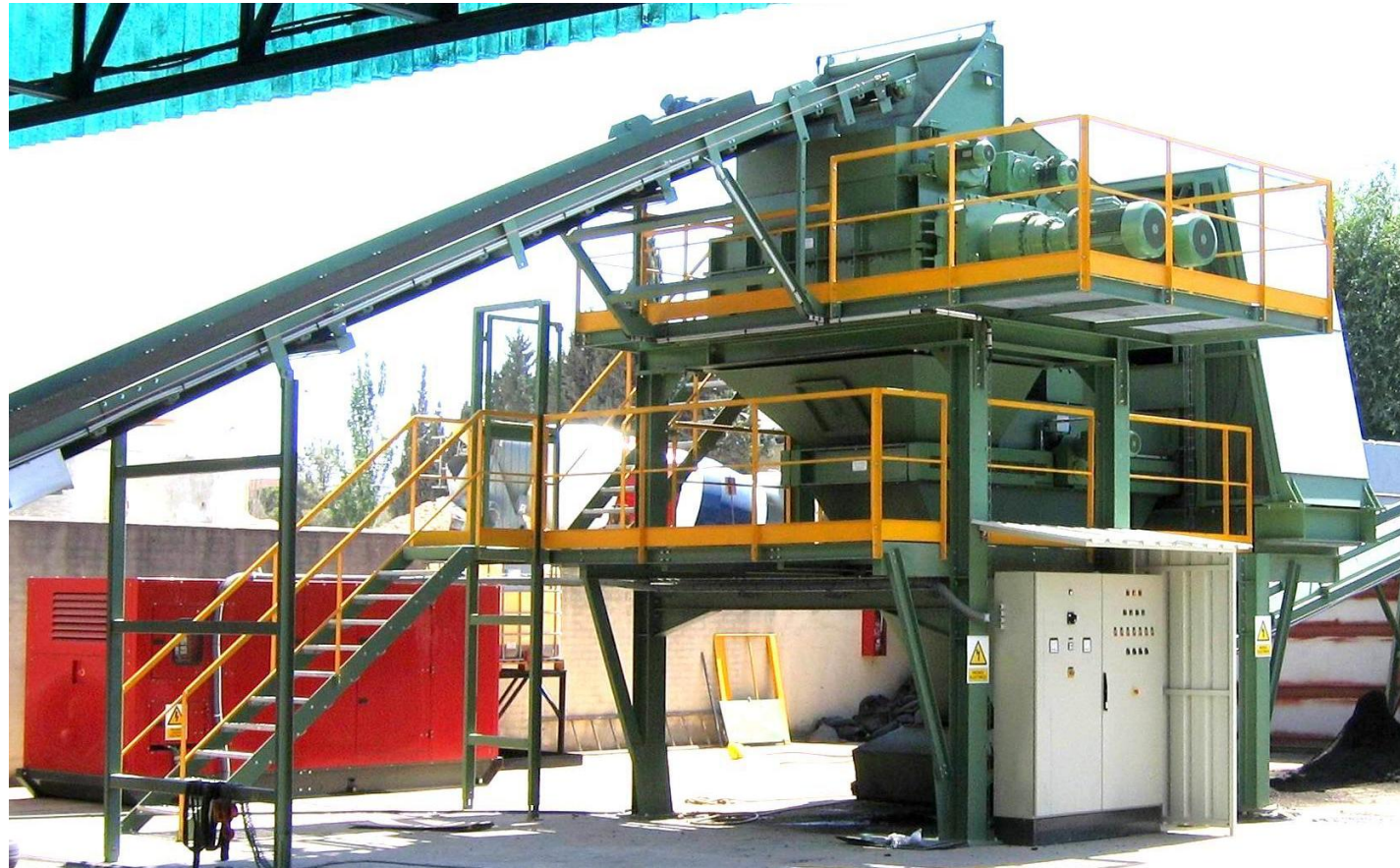

2 x 45 kW

PRECIMECA tyre shredders

**16-02-100 + 8-02-50 shredders to produce 100
& 50 mm chips from PC and truck tyres :**



2 x 45 + 2 x 55 kW

PRECIMECA tyre shredders

16-02-100 mobile shredder to produce 100 mm chips from PC and truck tyres :



PRECIMECA tyre shredders

RSP 1000 rasper to produce < 25 mm chips from PC and truck tyres :



1 x 250 kW

PRECIMECA tyre shredders

17-02-55 shredder for OTR and industrial waste



2 x 110 kW

PRECIMECA tyre shredders

Rotors Rapid Exchange System

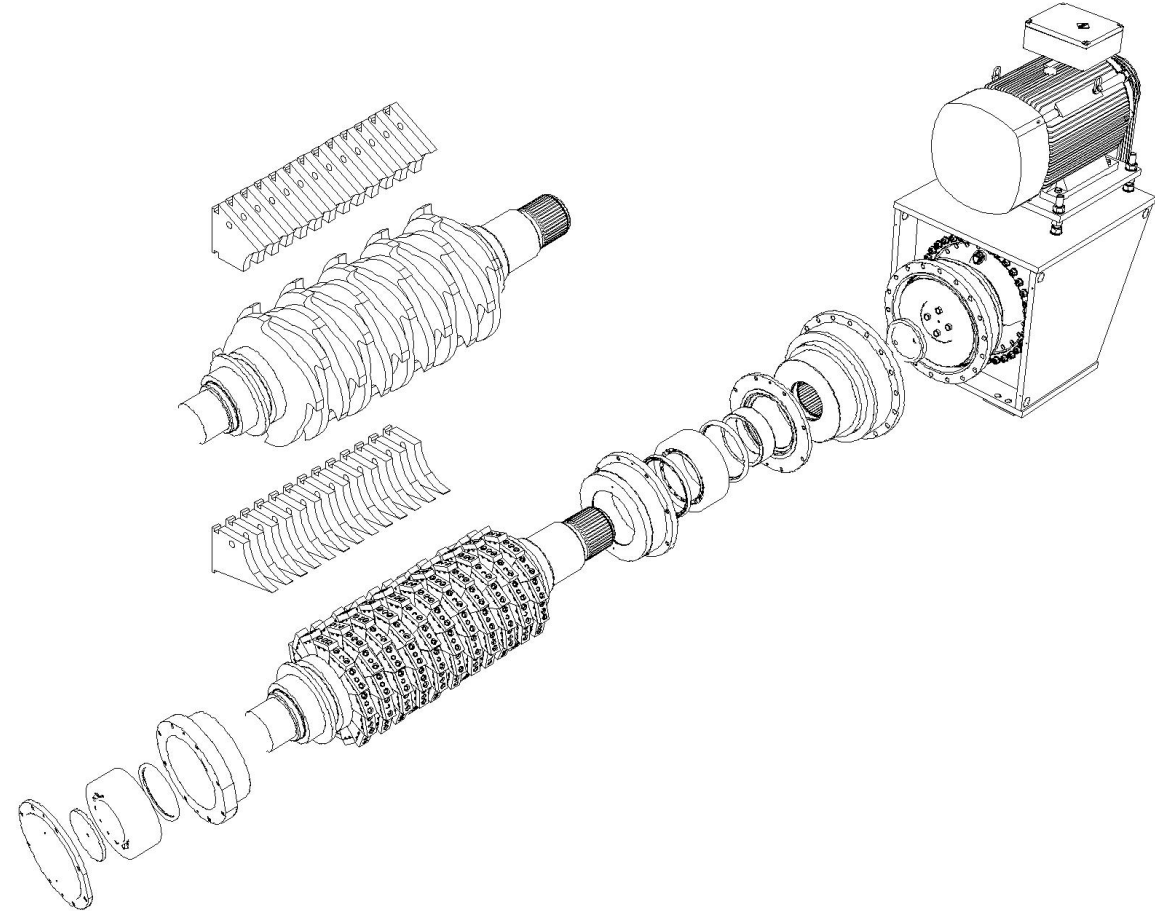
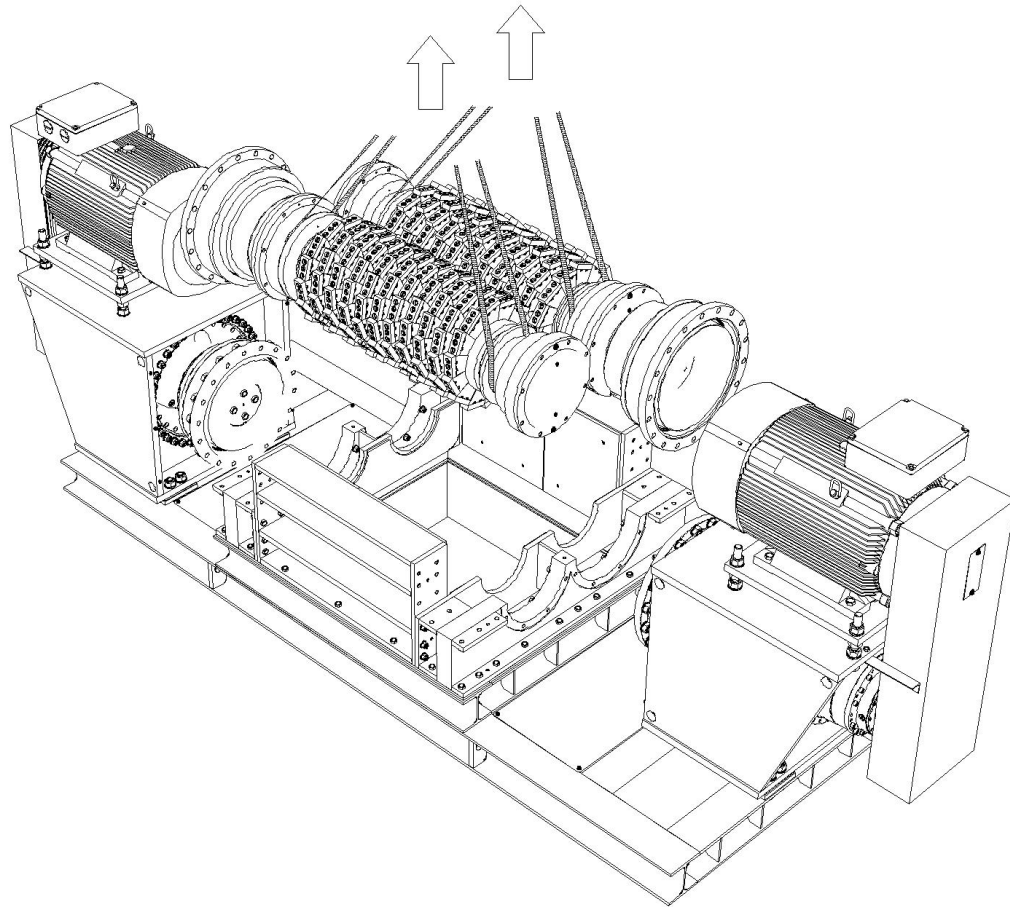

For more info, Contact us @

- www.precimeca.com
- <https://ftr.com.tr/en/default.asp?sayfa=urunkategori&c=AltKat&Kid=698>

FTR MAKİNA KİMYA METALURJİ A.Ş.

Tel : +90 216 3220080

E-mail : contact@ftr.com.tr