

# PRODUCT CATALOGUE FOR **CEMENT INDUSTRY**

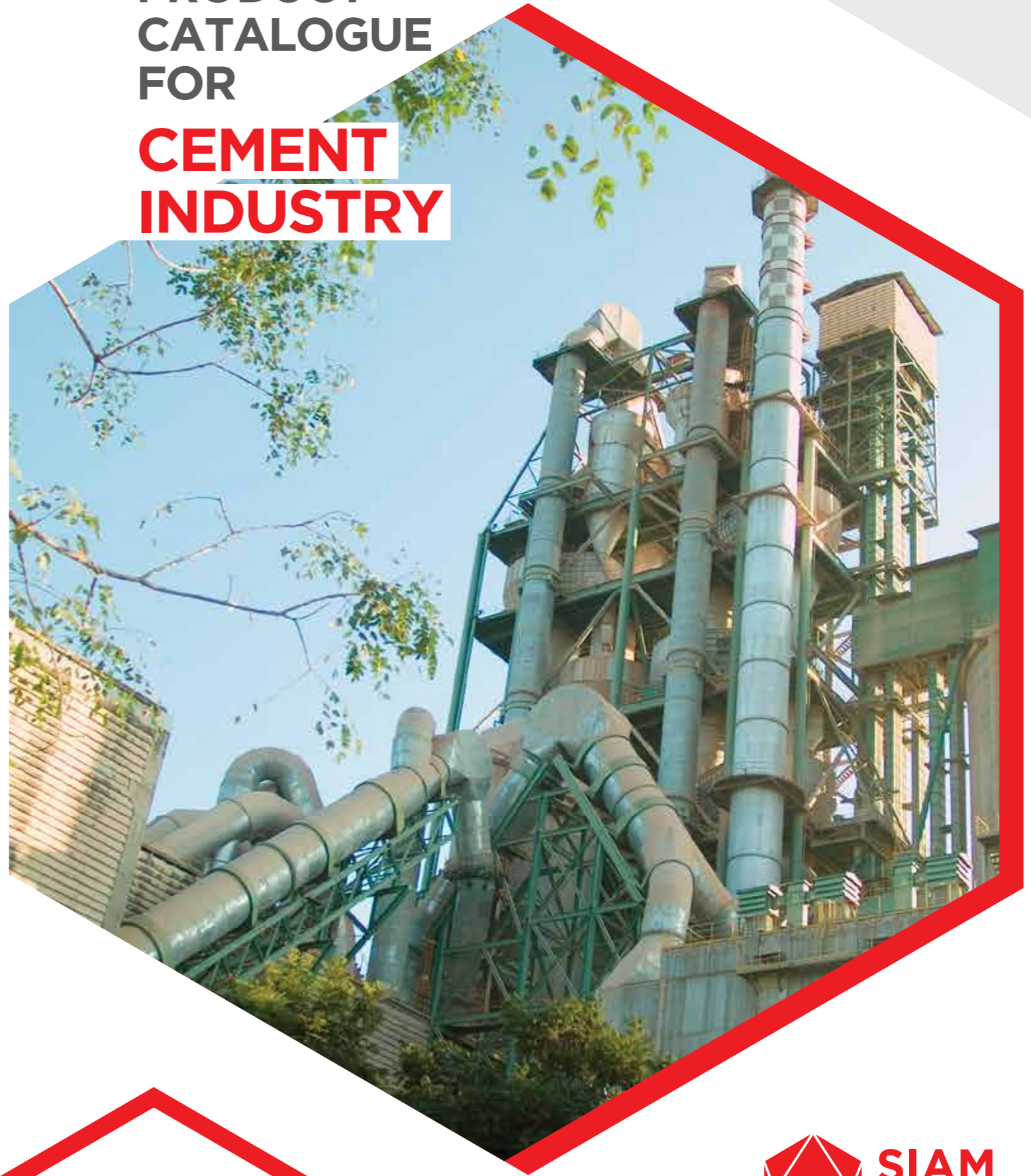

**THE SIAM REFRACTORY INDUSTRY CO., LTD.**  
1 Siam Cement Rd. Bangsue, Bangkok Thailand 10800  
E-mail: [srcmkt@scg.com](mailto:srcmkt@scg.com) | [www.siamrefractory.com](http://www.siamrefractory.com)



The given data are typical values of which the properties of the samples tested according to the procedure and standard of Siam Refractory generally accepted by our customers for many years. The given data cannot be used for specification or guarantee purpose. Siam Refractory reserves the right to update the given data and change our internal procedure and standard without any prior notice.

**Please request MSDS for safety information by contacting SRIC or authorized distributors**

# REFRACTORY SOLUTIONS TO FULFILL YOUR SUCCESS

The long accumulated experiences and know how in the Cement Industry have brought Siam Refractory a leading position to the point where it fully understands and realizes all aspects of customers' needs.

Hence, not only the World-Class Refractory products Siam Refractory offers, "but the Complete Refractory Solutions."



## Upper Cyclones

### Working Lining

K35, PH30AF  
CAST12, CAST13ES  
QUIKGUN-C12

### Insulation Lining

HI16, HI20  
CAST11LW  
QUIKGUN-LW11

### Anchoring system

Stainless Steel AISI 304

### Mortar

MORTAR 30AM(W)/(D)

## Middle Cyclones

### Working Lining

K35, PH30AF  
CAST12, CAST13ES  
QUIKGUN-C12

### Insulation Lining

HI16, HI20  
CAST11LW  
QUIKGUN-LW11  
CALCIUM SILICATE BOARD

### Anchoring system

Stainless Steel AISI 304

### Mortar

MORTAR 43AM(W)/(D)

## Lower Cyclones

### Working Lining (Normal Condition)

K35, K43  
CAST13ES, C40A  
CAST15ES  
QUIKGUN-C15,  
QUIKGUN-LC1550,  
QUIKGUN-SIC155  
QUIKSHOT-A60

### Working Lining (Severe Condition)

PH35AF, PH40AF, PH40AF-S5, PH40AF-S10  
C40A, ABRACAST40SIC, C-SIC300  
QUIKGUN-LC1550,  
QUIKGUN-SIC155  
QUIKSHOT-A60, QUIKSHOT30SIC

### Anchoring system

Stainless Steel AISI 310  
Stainless Steel 253MA

### Insulation Lining

IF135, HI16, HI20  
CAST11LW, CAST13LW  
QUIKGUN-LW11  
CALCIUM SILICATE BOARD

### Mortar

MORTAR 43AM(W)/(D)  
MORTAR 60AM(D)

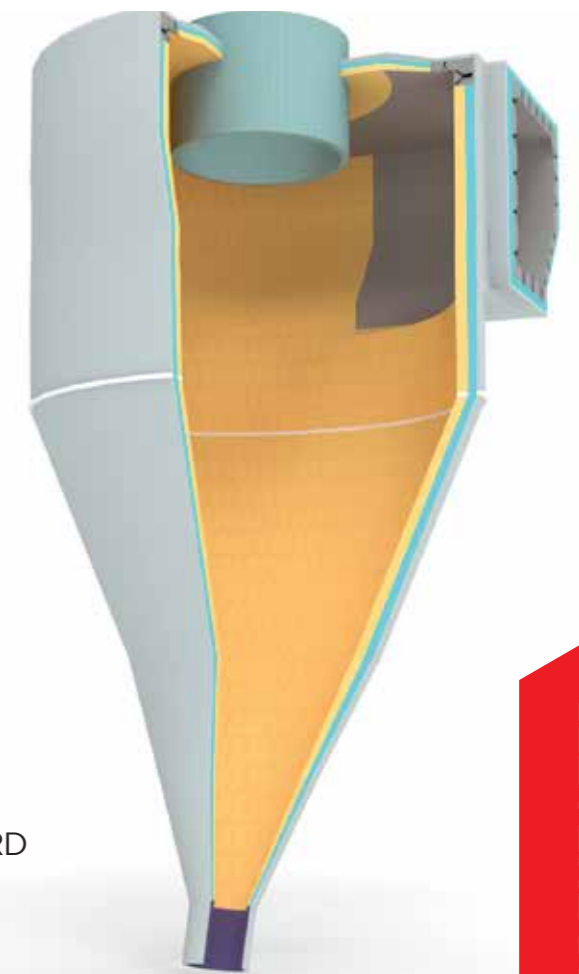

CYCLONE PREHEATER

### Color Code:

- Brick Lining
- Monolithic Lining

## CALCINER EXIT DUCT

### Working Lining

(Normal Condition)

K35, K43, KB60  
C40A, C60A  
CAST15ES  
QUIKGUN-LC1550  
SUPRAGUN155  
QUIKSHOT-A60

### Insulation Lining

IF135, HI16, HI20  
CAST11LW, CAST13LW  
QUIKGUN-LW11,  
QUIKGUN-LW13  
CALCIUM SILICATE BOARD

### Working Lining

(Severe Condition)

PH40AF  
PH40AF-S5, PH40AF-S10  
PH60AF-S5, PH60AF-S10  
C60A, ABRACAST40SIC  
ABRACAST60SIC, C-SIC300,  
C-SIC500  
QUIKGUN-LC1550,  
QUIKGUN-SIC155  
SUPRAGUN-S400  
QUIKSHOT-A60,  
QUIKSHOT30SIC

### Anchoring system

Stainless Steel AISI 310,  
Stainless Steel 253MA

### Mortar

MORTAR 43AM(W)/(D)  
MORTAR 60AM(D)

### Castable Lining

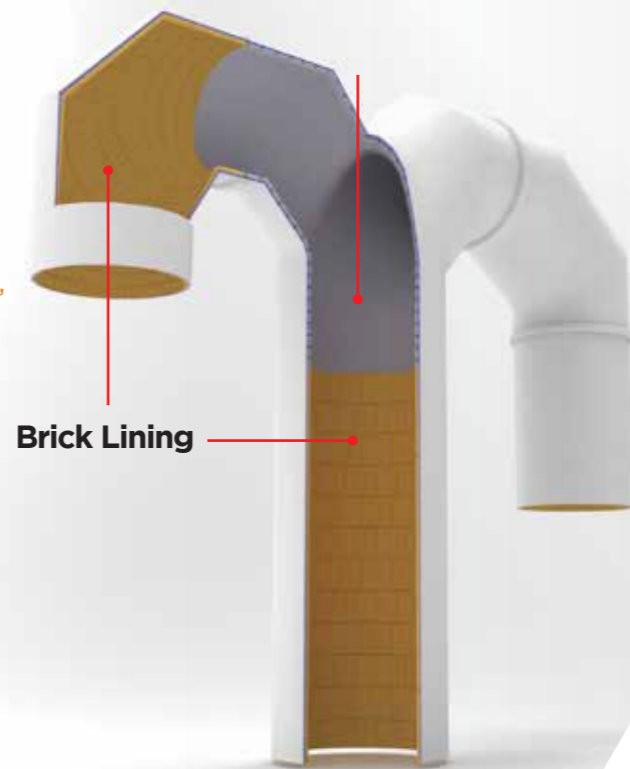

## KILN RISER DUCT/ KILN INLET CHAMBER

### Working Lining

(Normal Condition)

C40A, C60A  
QUIKGUN-LC1550  
QUIKSHOT-A60

### Working Lining

(Severe Condition)

C40A, C60A,  
ABRACAST40SIC  
ABRACAST60SIC,  
C-SIC300, C-SIC500  
QUIKGUN-LC1550,  
QUIKGUN-LC1650  
QUIKGUN-SIC155,  
SUPRAGUN-S400  
QUIKSHOT-A60,  
QUIKSHOT30SIC

### Insulation Lining

IF135, HI16, HI20  
CAST11LW, CAST13LW  
QUIKGUN-LW11, QUIKGUN-LW13  
CALCIUM SILICATE BOARD

### Anchoring system

Stainless Steel AISI 310  
+ Ceramic Anchor  
Stainless Steel 253MA  
+ Ceramic Anchor

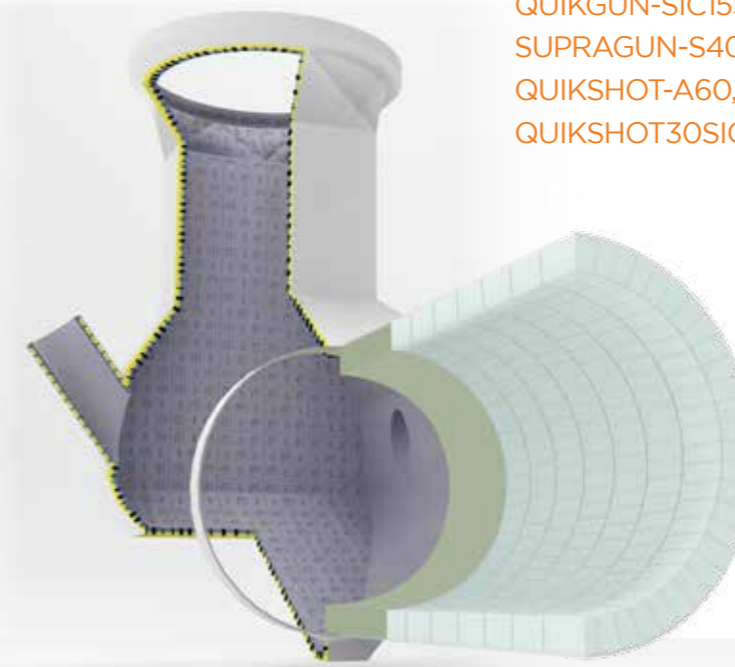

## CALCINER

### UPPER CALCINER

#### Working Lining

(Normal Condition)

K35, K43, KB60  
C40A, C60A  
CAST15ES  
QUIKGUN-LC1550  
SUPRAGUN155  
QUIKSHOT-A60

#### Anchoring system

Stainless Steel AISI 310  
Stainless Steel 253MA

#### Working Lining

(Severe Condition)

PH40AF  
PH40AF-S5, PH40AF-S10  
PH60AF-S5, PH60AF-S10  
C60A, ABRACAST40SIC  
ABRACAST60SIC,  
C-SIC300, C-SIC500  
QUIKGUN-LC1550  
QUIKGUN-SIC155,  
SUPRAGUN-S400  
QUIKSHOT-A60,  
QUIKSHOT30SIC

#### Insulation Lining

IF135, HI16, HI20  
CAST11LW, CAST13LW  
QUIKGUN-LW11,  
QUIKGUN-LW13  
CALCIUM SILICATE BOARD

#### Mortar

MORTAR 43AM(W)/(D)  
MORTAR 60AM(D)

### LOWER CALCINER

#### Working Lining

(Normal Condition)

K35, K43, KB60  
C40A, C60A  
CAST15ES  
QUIKGUN-LC1550  
SUPRAGUN155  
QUIKSHOT-A60

#### Anchoring system

Stainless Steel AISI 310,  
Stainless Steel 253MA

#### Working Lining

(Severe Condition)

PH40AF  
PH40AF-S5, PH40AF-S10  
PH60AF-S5, PH60AF-S10  
C60A, ABRACAST40SIC  
ABRACAST60SIC,  
C-SIC300, C-SIC500  
QUIKGUN-LC1550  
QUIKGUN-SIC155,  
SUPRAGUN-S400  
QUIKSHOT-A60,  
QUIKSHOT30SIC

#### Insulation Lining

IF135, HI16, HI20  
CAST11LW, CAST13LW  
QUIKGUN-LW11,  
QUIKGUN-LW13  
CALCIUM SILICATE BOARD

#### Mortar

MORTAR 43AM(W)/(D)  
MORTAR 60AM(D)

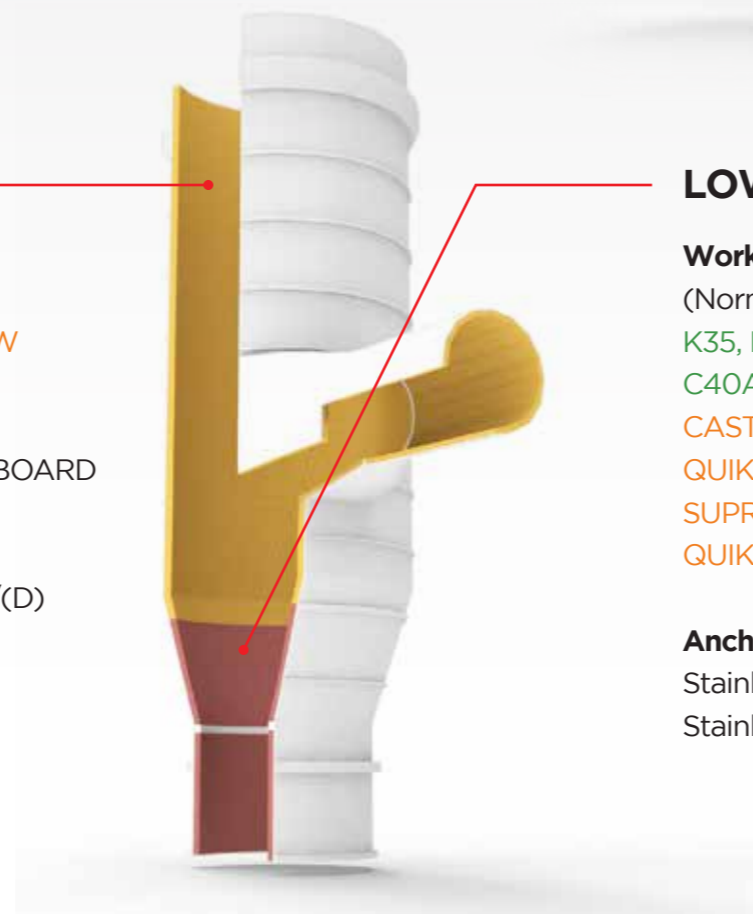

#### Color Code:

- Brick Lining
- Monolithic Lining

## Kiln Hood

### Working Lining

KB60  
KB70  
BX80  
BA85  
C60A,C70A  
NEOCAS1750  
TUFDURA-S300, TUFDURA-S600  
QUIKGUN-LC1650  
QUIKGUN-SIC155, SUPRAGUN-S400  
QUIKSHOT-A60, QUIKSHOT30SIC

### Anchoring system

Stainless Steel AISI 310  
+ Ceramic Anchor  
Stainless Steel 253MA  
+ Ceramic Anchor

### Insulation Lining

IF135, HI16,  
HI20, CAST11LW, CAST13LW  
QUIKGUN-LW11, QUIKGUN-LW13  
CALCIUM SILICATE BOARD

### Mortar

MORTAR 70AM(W)/(D)

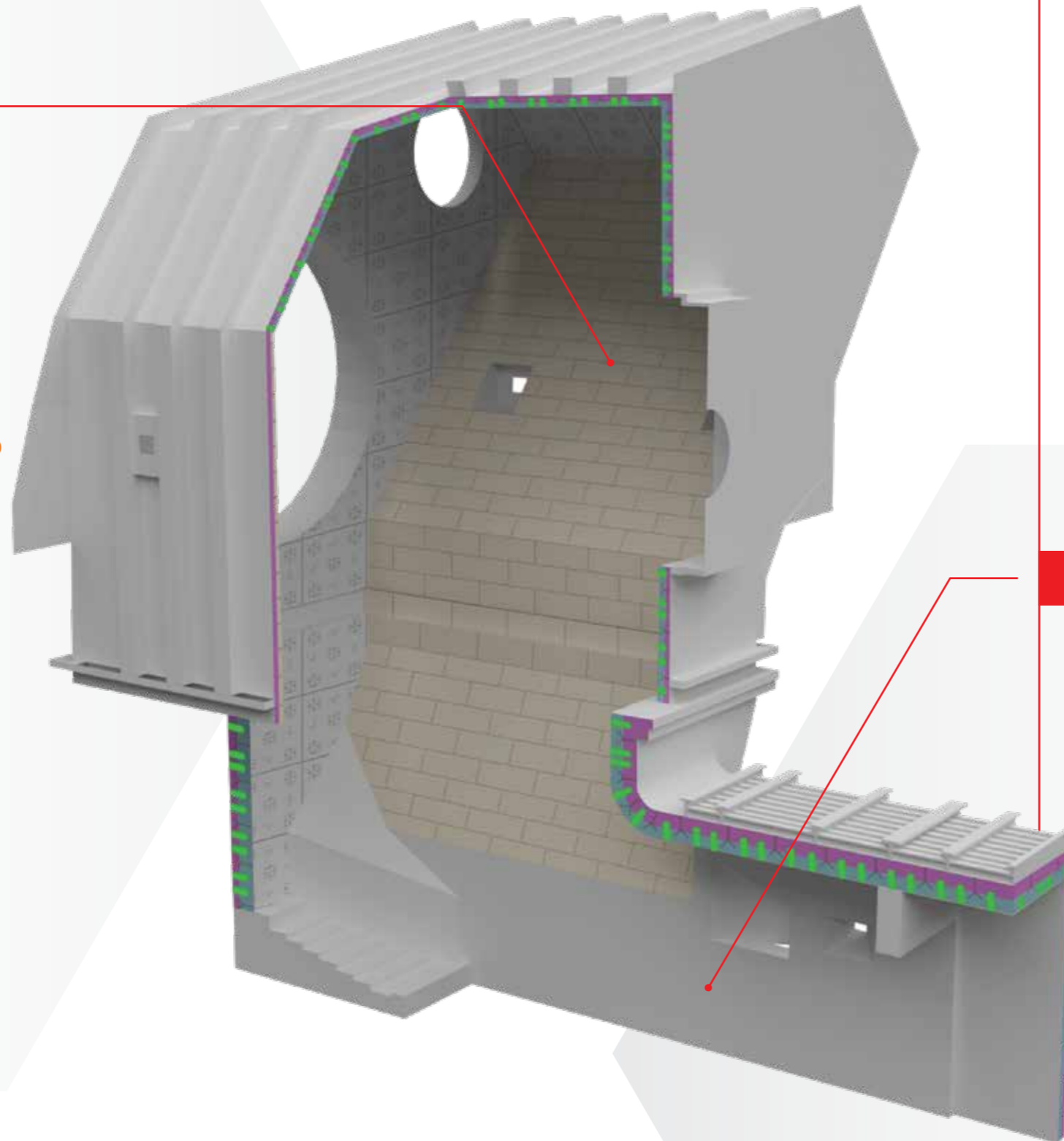

## Hot Section

### Working Lining

KB60  
KB70, BX80, BA85,  
C60A,C70A  
NEOCAS1750  
TUFDURA-S300,  
TUFDURA-S600  
QUIKGUN-LC1650  
QUIKGUN-SIC155,  
SUPRAGUN-S400  
QUIKSHOT-A60,  
QUIKSHOT30SIC

### Mortar

80AM(D),  
MORTAR 70AM(W)/(D)

### Insulation Lining

IF135, HI16,  
HI20, CAST11LW,  
CAST13LW  
QUIKGUN-LW11,  
QUIKGUN-LW13  
CALCIUM SILICATE BOARD

### Anchoring system

Stainless Steel AISI 310  
+ Ceramic Anchor  
Stainless Steel 253MA  
+ Ceramic Anchor

## Cooler

## Cold Section

### Working Lining

K35, K43, KB50, C40A,  
C60A, CAST15ES  
QUIKGUN-LC1550  
QUIKGUN-SIC155  
QUIKSHOT-A60

### Anchoring system

Stainless Steel AISI 304

### Insulation Lining

IF135, HI16,  
HI20, CAST11LW, CAST13LW  
QUIKGUN-LW11,  
QUIKGUN-LW13  
CALCIUM SILICATE BOARD

### Mortar

MORTAR 43AM(W)/(D)  
MORTAR 50AM(D)

KILN HOOD AND COOLER

### Color Code:

Brick Lining  
Monolithic Lining

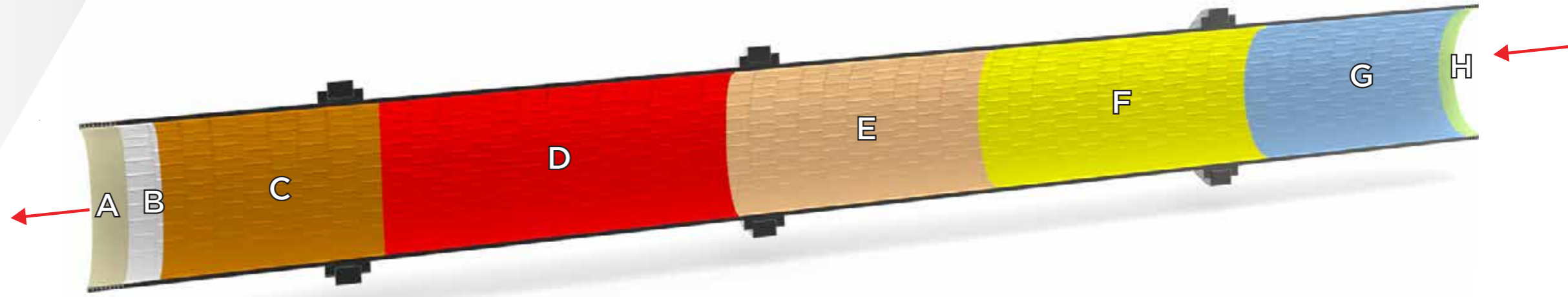

## Burner Pipe

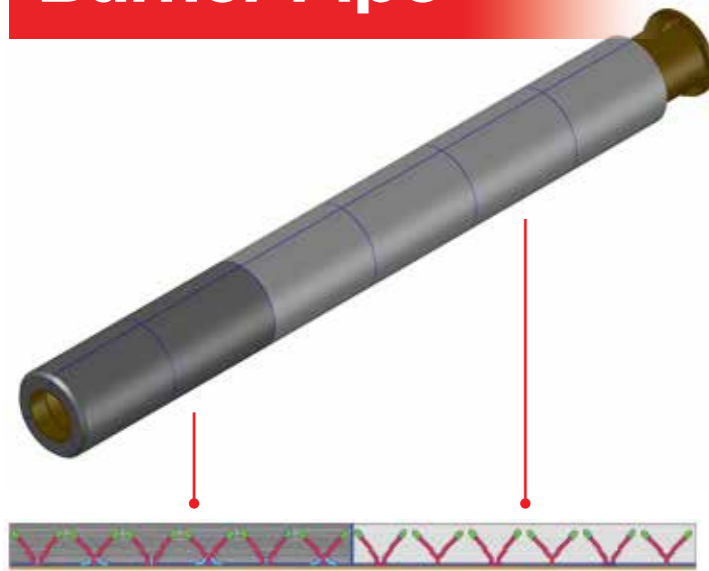

	Products
Normal Condition	C60A C70A
Severe Condition	TUFDURA-S300 TUFDURA-S600 (Mixed with 2% Stainless Steel Hook-End Fibers)
Anchoring system	Stainless Steel AISI 310, Stainless Steel 253MA with Omega Floating System at the tipsum

CONDITION LEVEL	A NOSE RING	B COOLING ZONE/ RETAINING RING AREA	C LOWER TRANSITION ZONE	D SINTERING/ COATING ZONE	E UPPER TRANSITION ZONE	F SAFETY ZONE	G PREHEATING/ CALCINING ZONE	H INLET CONE
NORMAL CONDITION	C60A C70A	BA85 BA85P BX80	MSN80 TUFMAG-AF NEOMAG-F MAGTHERM-F2	NEOMAG-F-HP NEOMAG-F NEOMAG-S90 MAGTHERM-F2	MSN80 TUFMAG-AF NEOMAG-F MAGTHERM-F2	KB60 KB70	K43 KB50	C40A C60A QUIKGUN-LC1550 SUPRAGUN155KN
MECHANICAL STRESS	TUFDURA-S300 TUFDURA-S600 (Mixed with 2% Stainless Steel Hook-End Fibers)	FLEXDURA-HP FLEXDURA	TUFMAG-XS TUFMAG-SP	NEOMAG-F MULTIMAG TUFMAG-AF NEOMAG-F-HP	TUFMAG-SP TUFMAG-XS	KB70 BX80 PH70AF	PH40AF	ABRACAST60SIC C-SIC300 C-SIC500 SUPRAGUN-S400
CHEMICAL ATTACK	TUFDURA-S300 TUFDURA-S600 (Mixed with 2% Stainless Steel Hook-End Fibers)	FLEXDURA TUFMAG-AF FLEXDURA-HP	MAGTHERM-F2 TUFMAG-AF TUFMAG-SP	NEOMAG-F NEOMAG-F-HP NEOMAG-S90 MULTIMAG MAGTHERM-F2	TUFMAG-SP TUFMAG-AF MAGTHERM-F2	PH70AF KEMRESIS KEMRESIS-S9	PH40AF KEMRESIS KEMRESIS-S9	ABRACAST60SIC C-SIC300 C-SIC500 SUPRAGUN-S400
MECHANICAL STRESS & CHEMICAL ATTACK	TUFDURA-S300 TUFDURA-S600 (Mixed with 2% Stainless Steel Hook-End Fibers)	FLEXDURA-HP FLEXDURA	TUFMAG-SP TUFMAG-XS MS80AF	MSN80 NEOMAG-F-HP MSN80S MULTIMAG TUFMAG-AF MAGTHERM-F2	TUFMAG-SP TUFMAG-XS MS80AF	KEMRESIS KEMRESIS-S9	PH40AF KEMRESIS KEMRESIS-S9	ABRACAST60SIC C-SIC300 C-SIC500 SUPRAGUN-S400
UNSTABLE COATING AND / OR ZONE SHIFTING	TUFDURA-S300 TUFDURA-S600 (Mixed with 2% Stainless Steel Hook-End Fibers)	TUFMAG-SP TUFMAG-AF TUFMAG-XS MS80AF	TUFMAG-SP TUFMAG-AF	TUFMAG-SP MSN80 MSN80S MULTIMAG TUFMAG-AF NEOMAG-F-HP	TUFMAG-SP TUFMAG-AF	PH70AF	PH40AF	ABRACAST60SIC C-SIC300 C-SIC500 SUPRAGUN-S400
ANCHORING SYSTEM	Stainless Steel AISI 310 Stainless Steel 253MA	N/A	N/A	N/A	N/A	N/A	N/A	Stainless Steel AISI 310 Stainless Steel 253MA
MORTAR	N/A	70AM(W)/(D) 80AM(D) MORTAR A75	M80AM(D) MORTAR A75	MSN80(D) MORTAR A75	M80AM(D) MORTAR A75	60AM(D) 70AM(W)/(D) 80AM(D) MORTAR A75	43AM(W)/(D) 50AM(D)	N/A

ROTARY KILN

### Color Code:

- Brick Lining
- Monolithic Lining

### Damper and Damper Housing

**Working Lining**

EXDURA-A85, CAST18  
(Mixed with 2%  
Stainless Steel  
Hook-End Fibers)

**Anchoring system**

Stainless Steel AISI 310,  
Stainless Steel 253MA

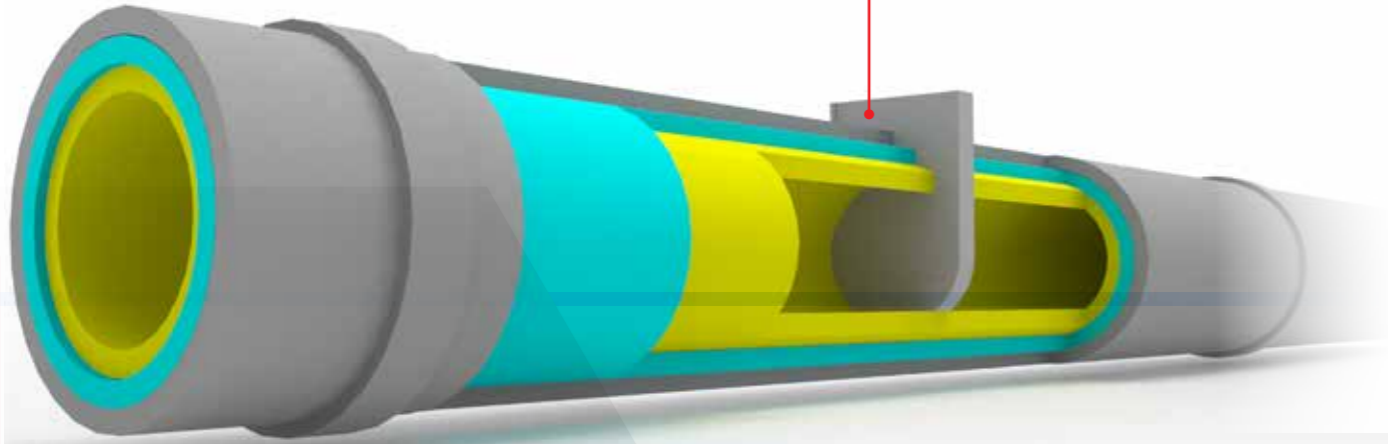

### Straight Duct

**Working Lining**

KB60, K43  
K25D, PH40AF  
PH40AF-S5  
PH40AF-S10  
KEMRESIS-S9

**Mortar**

MORTAR 43AM(W)/(D)  
MORTAR 60AM(D)

**Insulation Lining**

HI16, HI20, HI23  
CAST11LW, CAST13LW  
QUIKGUN-LW13  
QUIKGUN-LW11  
CALCIUM SILICATE BOARD

**Color Code:**

- Brick Lining
- Monolithic Lining

### Bend Portion

**Working Lining**

C40A, C60A,  
ABRACAST60SIC  
QUIKGUN-LC1550  
SUPRAGUN155KN  
QUIKGUN-LC1650  
SUPRAGUN165E  
QUIKGUN-SIC155  
QUIKGUN-SIC160  
CAST15ES  
QUIKGUN-C15  
QUIKSHOT-A60

**Insulation Lining**

HI16, HI20, HI23  
CAST11LW, CAST13LW  
QUIKGUN-LW13  
QUIKGUN-LW11  
CALCIUM SILICATE BOARD

**Anchoring system**

Stainless Steel AISI 310  
Stainless Steel 253MA

# Anti-Hydration Bricks

## The Unparalleled Solution to Storage & Handling of Magnesia-Based Bricks.



- Increased resistance to Hydration reaction by preventing water and/or moisture to MgO.
- No change in brick quality, properties, performance after Anti-Hydration treatment.
- No special care for transportation, storage condition, handling, package etc. are required anymore.
- Anti-Hydration treatment is available for any type of SRIC Magnesia-Based Brick.



### Placing Bricks in Garden under Humid Condition, Sun and Rain



After **5** months



After **15** months

*Without  
Anti-Hydration  
Treatment*



After **57** months

*With  
Anti-Hydration  
Treatment*

### Anti-Hydration as Options to Fit your Plant

#### APPLY...

- To your entire Basic brick order to get rid of all special cares and limited shelf life.
- To your spare lining order (for emergency) to get rid of the risk of brick expiration if not used within shelf life.

#### SAVE...

- Cost of disposing of expired and hydrated bricks.
- Cost and time of sorting good bricks from hydrated bricks.
- Production losses due to bricks failure as a result of hydrated bricks being installed.



**PAN MIXER** (Capacity up to 250 kg/batch)

- Replaceable Wear-Resistant Liners
- Skid mounted for forklift transport
- Electrical circuitry to Safe Guarding of Machinery
- Safety cutout switch when lid is opened
- Capable of batch quantities of up to 250 kg of dense refractory castable
- 10 KW (15Hp) 380V 3 Phase 50Hz IP55 motor ratio 1:40
- Bag Breaker

**BRICK CUTTING MACHINE**

- Length / Width / Height = 1480 / 610 / 1550 mm.
- Weight: 165 kg
- Table size: 580X420 mm
- Compatible for Cutting Blade size: 14 - 20 inches
- Capable of Cutting both Alumina and Basic Bricks (both wet and dry cutting)
- Cutting Wheel Motor: 400V / 4KW / 5.5HP
- Generator: 16A / 10kVA
- Cutting Wheel (max blade dia. / blade bore = 20 inches / 1 inch)

**LASER WELDED DIAMOND BLADES**

- Laser welded diamond blade for refractory is manufactured by laser welding technology with key slot and drop segment for undercut protection which enables the blade to cut refractory material with both wet and dry cutting process.
- Super Premium Grade (Blue Color) is recommended for general cutting works.
- Professional Grade (White Color) is for professional user where cost per cut is the prime consideration.

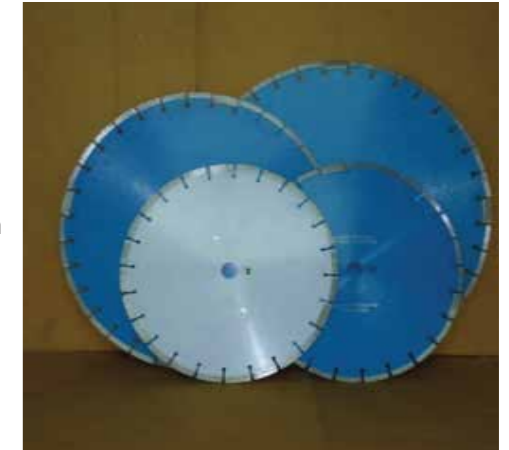

**SKILL OF TEAMWORK  
SPIRIT OF SYNERGY**

**ENGINEERING**

- Engineering of Refractory Drawings
- Best-Practice Lining Design
- Calculation of Material Requirement

**INSTALLATION**

- Quality and Timely Installation
- Installation by Well-Trained Installers

**SUPERVISION**

- Inspection for Repair
- Planning of Refractory Installation
- Supervision during Refractory Installation
- Consultancy & Recommendation & Problem Solving

**GUNNING MACHINE (REED-LOVA)**

- Lova Gunite Machine is an air driven, dry-mix gunning machine.
- The Lova provides a steady flow of material which allows uniform hydration and very smooth placement.
- The adjustable output of material may be increased without sacrificing the quality of the application.
- Maximum horizontal conveying distance 305 m & vertical distance is 91 m.

**Features:**

- Continuous feed hopper with bag breaker
- 2 blade or 5 blade agitator
- Optional electric drive motor
- Optional hopper safety hood
- Optional dust suppression system
- Made in the U.S.A.



In partnership with Bricking Solutions, a division of Brokk, an American professional manufacturer of customized rotary kiln bricking machines and related equipment, Siam Refractory provides customized designs of bricking machines and equipment to meet your unique requirements for various kiln designs in cement plant.

## NEW EZ Flexx50 BRICKING MACHINE

### Kiln Diameter 3.6M - 7.6M

Designed, Engineered, and Manufactured in the U.S.A.

- Bricking Solutions' newest and best bricking machine, designed by professional engineers.
- Frames and structural components on the new machine design are manufactured from 6061-T6 aircraft grade aluminum - the lightest total weight in the industry.
- Flexible arch allows for easy adjustment inside the kiln for either minor kiln distortion, or to accommodate conical sections or kiln shell deformation.
- With a wide variety of additional features for added efficiency, not only is it the safest bricking machine in the industry, it is also the best.

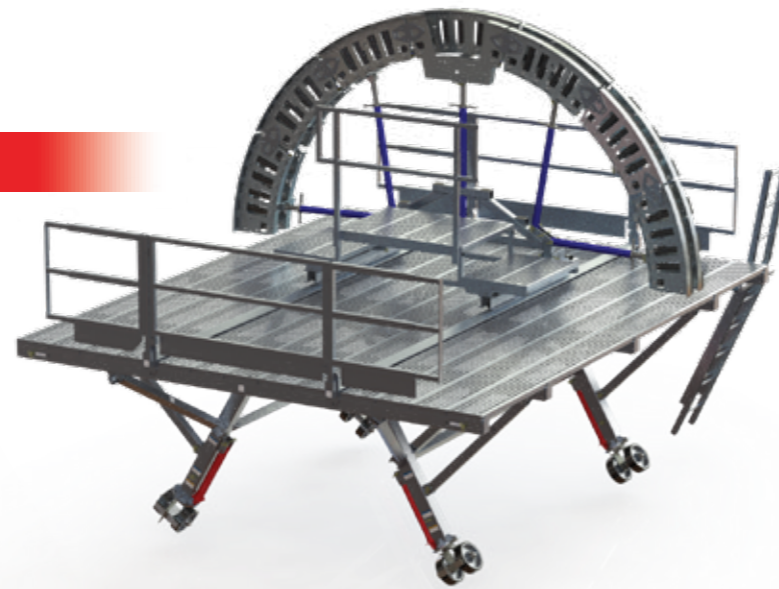

- Components fold for easy storage and new Symmetrical part design have pin connections for fast and easy assembly.
- Come with a standard 4,000 kg (8,800 lb) load capacity and 4.3 m (14") work platform. Allows for 2 pallets of bricks (1,540 kg) plus men and equipment - Highest load capacity in the industry.
- New arch trolley design that utilizes simple jack screws to allow for easy adjustment of distance between arch and shell.
- An ergonomic stair step design is incorporated in the arch trolley and moves a rail system the entire length of the work platform.
- Ergonomic Cut-Away Keying Section, exclusive to Bricking Solutions, gives the Key Mason easy access to down-kiln arch giving a clear view for critical key brick installation.
- The segmented double arch, screw jacks and arch hinges allow for adjustments on the fly and it is the only bricking machine in the industry that fully adjusts inside the kiln for distortion and tapers.
- New engineered cut-outs incorporation into arch panels for the lightest arch in the industry and new cylinders are field repairable.

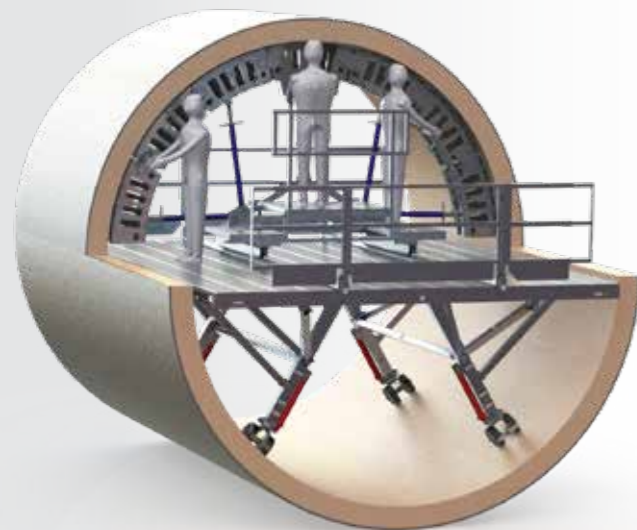

## EZ LIFT PLATFORM SAFE & INNOVATIVE PLATFORM

Designed, Engineered, and Manufactured in the U.S.A.

- Modular structure high-strength aluminum components designed to provide a flexible, maneuverable work platform for personnel and equipment in vertical vessels.
- Platform Capacity: 6,000 lbs (2,722 kg) (personnel and material)
- Platform Weight: ~ 1,000 lb - 2,500 lb (450 kg - 1,100 kg)
- Raise/Lower Speed: 35ft/min (11m/min) with SC series electric hoists.
- Compatible w/ manual winches, electric, hydraulic or air powered hoists 1,500 lb (680 kg) max capacity.
- Requires 6 wire ropes anchored at the top of the vessel; roof or walls.
- The platform can be configured in 3 different structural sizes.
- Only the inner and outer radial beams are changed.
- Custom outer panels provides fit to vessel walls.
- Outriggers extend up to 40" [1 meter] to stabilize and maneuver platform".

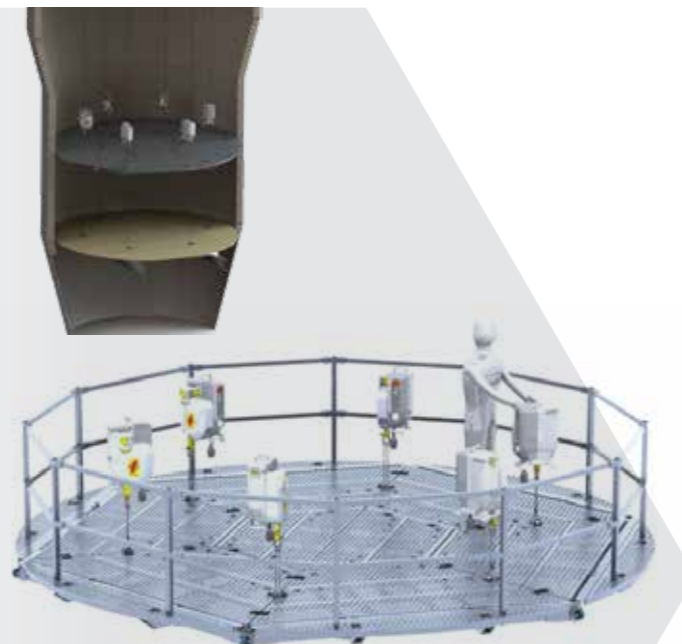

## CUSTOM KILN ACCESS RAMP

- Supports 6,804 kg (15,000 lb) live load capacity with a 3:1 safety factor which allows working demolition equipment and fork truck access.
- 9 mm (3/8") non skid diamond plate decking and heavy duty fall guards.
- Modular design allows quick installation (2-3 hours approx.)
- Each ramp is designed by certified professional engineers, built for your specific kiln and made with high grade 6061 T6 aluminum.



## BEDDING CART

- Speed up bedding out larger kilns while providing a safe, ergonomic working deck with stair steps for higher brick placement.
- Stair step ergonomically design reduces fatigue and increases productivity.
- Custom designed and engineered to meet needs of each plant.
- 2,721 kg (6,000 lb) capacity deck with large working space allowing room to stack brick.
- Big castors with kick brake for easy and fast movement of cart, brick, and tools as bedding brick is installed.



## RADIALIGN BRICK ALIGNMENT DEVICE

- The Radialign laser ensures the precise placement of each row of brick.
- The Radialign can be assembled and ready for use in less than 30 minutes.
- The Radialign produces a continuous laser light parallel to kiln's axis which is intercepted by a rotating pent a-prism device.
- This refracts the laser perpendicular onto the circumference of the kiln shell.
- This line can be marked at points along the kiln, which are then used as an exact reference for installation of the refractory.



## SAFETY INSPECTION CAGE 2-MAN OR 4-MAN

- 4-Man Cage can be easily carried by 4 people using flip-up handles.
- 2-Man Cage can be easily carried by 2 people using flip-up handles attached to a safety gate and shoulder harnesses is standard for increased stability.
- 1.5 M (5 ft) of portable protection designed & certified by a professional engineer.
- Rated for 114 kg (250 lb) dropped from 60 cm (24") with a 3:1 safety factor. A shock absorbed panel increase safety.



## CONVEYOR

### 305 MM (12") - 508 MM (20") - 762 MM (30") Width

- All-aluminum, modular conveyor system designed for portability, easy set up, and trouble free performance.
- Reduces or eliminates brick damage due to handling.
- System can be set up on the ground, springboards, or elevated on standard adjustable legs.
- Belt sections are easily assembled with hinged lacing and spring pin design.
- Lengths up to 85 m (280ft) and widths of 30.5 cm (12"), 50.8 cm (20"), and 76.2 cm (30") available.



## LONG JACK

- Pneumatically operated hydraulic jack with pressure gauge for consistent installation pressure on each ring of brick.
- Swivel foot braces adjust automatically to brick angle.
- Optional finger-tip control located on jack for ease of use & safety.

## SHIM DRIVER

- Pneumatic hammer with shim driving head.
- Slotted shim driver head allows for high impact on shim & ensure tight radial installation safety.

## MORTARS

Properties of Products	Mortars											
	30AM(W)	30AM(D)	43AM(W)	43AM(D)	50AM(D)	60AM(D)	70AM(W)	70AM(D)	80AM(D)	MORTAR-A75	M80AM(D)	
<b>Physical Properties: (Typical)</b>												
Refractoriness (Orton Cone)	28-29	28-29	31.5-32	31.5-32	32	35	36-37	36-37	38	>38	>38	
Approximate Amount Required per 1000, 9" Pieces												
Standard Equivalent (Thinly Trowelled Joints) kg	215	160	210	170	180	190	230	210	220	165	175	
Modulus of Rupture kg/cm <sup>2</sup>	25	20	25	20	22	23	25	25	27	60	20	
Refractoriness Test : Mortar does not squeeze or flow from joints when heated for 5 hrs at °C												
	1500	1500	1600	1600	1600	1600	1650	1650	1650	1700	1600	
<b>Chemical Composition:</b>												
Alumina (Al <sub>2</sub> O <sub>3</sub> )	35.0	38.0	43.5	44.0	50.0	60.0	65.0	68.5	80.0	75.0	2.3	
Silica (SiO <sub>2</sub> )	57.0	54.0	52.0	51.0	46.0	35.0	27.0	27.5	15.0	20.0	11.5	
Iron Oxide (Fe <sub>2</sub> O <sub>3</sub> )	1.8	1.8	1.5	1.5	1.8	1.8	2.0	2.0	1.8	2.5	2.0	
Magnesia (MgO)	-	-	-	-	-	-	-	-	-	-	79.5	

## INSULATING BRICKS

Properties of Products	Insulating Bricks			
	HI 16	HI 20	HI 23	IF 135
<b>Physical Properties: (Typical)</b>				
Maximum Service Temperature °C	850	1100	1260	1300
Bulk Density kg/cm <sup>3</sup>	640	740	760	800
Cold Crushing Strength kg/cm <sup>2</sup>	20	25	23	30
Modulus of Rupture kg/cm <sup>2</sup>	10	10	6	20
Reheat Test, Permanent Linear Change %	-0.5	-0.5	-0.7	-0.20
<b>After Heating at</b>				
Thermal Conductivity				
at 400°C (W/m.K)	0.13	0.14	0.17	0.33
at 600°C (W/m.K)	0.14	0.15	0.19	0.36
<b>Chemical Composition:</b>				
Alumina (Al <sub>2</sub> O <sub>3</sub> ) %	9.0	6.0	25.0	41.0
Silica (SiO <sub>2</sub> ) %	48.0	39.0	45.0	55.0
Lime (CaO) %	36.0	48.0	25.0	0.5
Iron Oxide (Fe <sub>2</sub> O <sub>3</sub> ) %	1.2	1.2	1.5	1.0

## FIRECLAY, HIGH ALUMINA AND BASIC BRICKS

Properties of Products	Fireclay Bricks											High Alumina										Basic Bricks															
	K25D	K30	K35	K43	PH30AF	PH35AF	PH40AF	PH40AF-S5	PH40AF-S10	FLEXDURA	FLEXDURA-HP	KB50	KB60	KB70	KB60PB	BX80	BA85	BA85P	PH60AF-S5	PH60AF-S10	PH70AF	KEMRESIS	KEMRESIS-S9	MSN80	MS80AF	MULTIMAG	TUFMAG-AF	TUFMAG-XS	TUFMAG-SP	NEOMAG-F	NEOMAG-F-HP*	MAGTHERM-F2**					
<b>Physical Properties: (Typical)</b>																																					
Refractoriness (Orton Cone)	28	29-30	31.5-32	33-34	19-20	27-28	32-32.5	32-32.5	32	31	31	34-35	35-36	36-37	35-36	38	>38	>38	34	34	36	37	>38	>38	>38	>38	>38	>38	>38	>38	>38	>38	>38	>38			
Bulk Density kg/m <sup>3</sup>	2250	2200	2200	2260	2150	2200	2250	2260	2260	2640	2620	2370	2500	2550	2610	2720	2960	2860	2450	2490	2650	2580	2680	2880	2970	2900	2900	2900	2980	2880	1880	2790					
Apparent Porosity %	12.0	18.0	18.0	18.0	14.0	14.0	15.0	15.0	15.0	14.0	14.0	18.0	18.0	18.0	13.0	19.0	15.0	17.0	18.0	16.0	18.0	16.0	17.0	17.5	14.0	16.0	16.5	16.5	15.0	17.0	17.0	15.5					
Cold Crushing Strength kg/cm <sup>2</sup>	525	275	350	350	450	470	450	450	450	700	700	450	500	530	800	700	1050	1050	500	650	700	600	750	500	500	650	600	600	600	550	550	500					
Modulus of Rupture kg/cm <sup>2</sup>	100	45	50	80	100	90	80	80	80	65	80	85	85	110	130	120	250	200	70	80	110	70	80	50	50	60	60	55	60	60	60	75					
<b>Chemical Composition:</b>																																					
Alumina (Al <sub>2</sub> O <sub>3</sub> ) %	36.0	36.0	38.5	46.0	31.0	37.0	41.5	41.5	41.5	45.0	45.0	52.0	61.5	70.0	60.0	80.5	85.0	85.0	55.0	56.0	70.0	63.0	70.0	13.5	13.5	12.0	10.5	17.5	10.5	12.5	8.0	12.5					
Silica (SiO <sub>2</sub> ) %	58.0	59.6	57.5	50.0	63.0	57.0	53.0	48.0	43.0	28.5	26.0	43.5	34.0	25.0	34.0	13.5	9.0	9.0	34.0	30.0	25.0	25.6	15.0	0.1	0.4	0.7	0.5	0.5	0.5	0.5	0.5	21.0					
Magnesia (MgO) %	-	-	-	-	-	-	-	-	-	-	-	-	-	-	-	-	-	-	-	-	-	-	-	85	84.5	85	87	80	87	80	88	60					
Iron Oxide (Fe <sub>2</sub> O <sub>3</sub> ) %	1.4	1.2	1.3	1.3	1	1	1.0	1.0	1.0	1.0	1.0	1.3	1.4	1.4	1.5	1.5	1.2	2.0	1.5	1.5	1.4	1.6	1.2	0.5	0.6	0.6	0.5	0.5	0.5	4.0	1.5	5.5					
Alkalies (Na <sub>2</sub> O+K <sub>2</sub> O+Li <sub>2</sub> O) %	1.3	0.7	0.6	0.7	2.8	2	1.5	1.5	1.5	-	-	-	-	-	-	-	-	-	-	-	-	-	-	-	-	-	-	-	-	-	-	-					
Silicon Carbide (SiC) %	-	-	-	-	-	-	-	5.0	10.0	25.0	25.0	-	-	-	-	-	-	-	5.0	10.0	-	7.0	9.0	-	-	-	-	-	-	-	-	-					
Chromic Oxide (Cr <sub>2</sub> O <sub>3</sub> ) %	-	-	-	-	-	-	-	-	-	-	-	-	-	-	-	-	-	-	-	-	-	-	-	-	-	-	-	-	-	-	-	-					
Lime (CaO) %	-	-	-	-	-	-	0.8	0.8	0.8	-	-	-	-	-	-	-	-	-	-	-	-	-	-	0.8	1.0	1.4	1.2	1.1	1.2	2.5	1.2	0.5					
Titania (TiO <sub>2</sub> ) %	-	-	-	-	-	-	-	-	-	-	-	1.40	1.80	2.40	1.50	2.70	2.20	2.50	1.80	1.20	1.50	1.60	2.50	-	-	-	-	-	-	-	-	-					
Phosphorous Pentoxide (P <sub>2</sub> O <sub>5</sub> ) %	-	-	-	-	-	-	-	-	-	-	-	-	-	-	2.5	-	-	-	-	-	-	-	-	-	-	-	-	-	-	-	-	-					

# CASTABLES

Properties of Products	Light Weight Castables		Conventional Castables				Low Cement Castables											
	CAST11LW	CAST13LW	CAST12	CAST13ES	CAST15ES	CAST18	NEOCAS1750	C40A	C60A	C70A	C-SIC300	C-SIC500	TUFDURA-S300	TUFDURA-S600	EXDURA-A85	ABRACAST40SIC	ABRACAST60SIC	
<b>Type</b>	Light Weight	Light Weight	Normal Strength	Extra Strength	Extra Strength	High Erosion Resistance	LCC	LCC, Alkali Resistance	LCC, Alkali Resistance	LCC, Alkali Resistance	LCC with SiC, Alkali Resistance	LCC with SiC, Alkali Resistance	LCC with SiC, Alkali Resistance	LCC with SiC, Alkali Resistance	LCC, High Erosion Resistance	LCC with SiC, Alkali Resistance	LCC with SiC, Alkali Resistance	
<b>Physical Properties: (Typical)</b>																		
Maximum Service Temperature	°C	1100	1300	1200	1300	1500	1800	1750	1400	1500	1600	1400	1500	1500	1500	1600	1400	1500
Approximate Weight Required for Casting, Gunning	kg/cm <sup>3</sup>	870	1300	1900	1900	2080	2590	2900	2300	2500	2700	2550	2700	2705	2595	2820	2250	2650
Approximate Amount of Water Required for Casting	%	50.0	30.0	11-13	13-15	11-13	9-11	5.0-6.0	5.0-6.0	4.5-5.5	4.5-5.5	6.0-6.5	4.5-5.5	5.5-6.0	5.0-5.5	5.0-5.5	7.0-8.0	5.5-6.5
Bulk Density, After Drying at 110 °C	kg/cm <sup>3</sup>	900	1400	2000	2115	2150	2800	2920	2320	2520	2720	2500	2750	2730	2620	2940	2280	2550
Modulus of Rupture, After Drying at 110 °C	kg/cm <sup>2</sup>	7	25	50	80	80	100	80	65	85	95	100	140	130	150	180	110	85
Cold Crushing Strength, After Drying at 110 °C	kg/cm <sup>2</sup>	40	125	250	450	400	650	550	550	750	800	550	900	750	800	850	510	500
Permanent Linear Change	%	-1.5	-0.04	+0.50	+0.50	-1	-0.5	+0.15	+0.10	+0.40	+0.40	0.2	+0.15	+0.50	+0.20	-1	-0.2	+0.5
After Heating at	°C	1040	1260	1200	1260	1480	1760	1750	1400	1500	1500	1400	1500	1500	1500	1500	1000	1500
<b>Thermal Conductivity</b>																		
at 400 °C	(W/m.K)	0.3	0.4	1.2	1.2	1.2	1.9	2.6	1.2	1.9	2.2	2.7	5.2	4.6	11.3	2.9	1.2	2.0
at 600 °C	(W/m.K)	0.3	0.4	1.2	1.2	1.3	1.9	2.3	1.3	1.9	2.1	2.5	5.0	4.7	13.1	2.6	1.3	2.0
at 1000 °C	(W/m.K)	0.4	0.4	1.3	1.3	1.4	1.9	2.2	1.4	1.9	2.0	2.5	5.0	4.8	14.4	2.5	1.4	2.2
<b>Chemical Composition:</b>																		
Alumina (Al <sub>2</sub> O <sub>3</sub> )	%	14.5	41.0	26.0	36.0	50.0	93.5	85.0	44.0	60.0	70.0	38.0	33.5	48.0	25.0	84.0	43.0	58.0
Silica (SiO <sub>2</sub> )	%	54.5	42.0	60.0	50.0	37.0	0.2	7.0	52.0	35.0	25.0	27.0	13.7	18.0	-	9.4	43.0	26.0
Iron Oxide (Fe <sub>2</sub> O <sub>3</sub> )	%	0.5	1.5	1.5	1.5	1.5	0.2	1.1	1.1	1.4	1.8	-	-	0.6	0.4	1.2	-	0.8
Silicon Carbide (SiC)	%	-	-	-	-	-	-	-	-	-	-	30.0	50.0	30.0	58.5	-	10.0	10.0
Lime (CaO)	%	29.0	12.5	9.0	9.5	10.0	5.5	1.6	1.5	1.5	1.7	1.5	-	1.3	1.3	2.1	1.5	1.3

# GUNNING MATERIALS AND SHOTCRETE

Properties of Products	Light Weight Gunning Materials			Conventional Gunning Materials				Low Cement Gunning Materials								Shotcrete	
	QUIKGUN-LW11	QUIKGUN-LW13	QUIKGUN-LW14	SUPRAGUN-S400	QUIKGUN-C12	QUIKGUN-C13	QUIKGUN-C15	QUIKGUN-LC1550	QUIKGUN-LC1650	SUPRAGUN155	SUPRAGUN155KN	SUPRAGUN165E	QUIKGUN-SIC155	QUIKGUN-SIC160	QUIKSHOT-A60	QUIKSHOT30SIC	
<b>Type</b>	Insulating Gunning	Light Weight Gunning	Light Weight Gunning	Silicon Carbide Gunning	Fireclay Gunning	Fireclay Gunning	Hight Alumina Gunning	Low Cement Gunning	Low Cement Gunning	Low Cement Gunning	Low Cement Gunning, Alkali Resistance	Low Cement Gunning, Alkali Resistance	Low Cement Gunning, Alkali Resistance	Low Cement Gunning with SiC, Alkali Resistance	Low Cement Gunning with SiC, Alkali Resistance	Wet Shotcrete, Alkali Resistance	Wet Shotcrete with SiC, Alkali Resistance
<b>Physical Properties: (Typical)</b>																	
Maximum Service Temperature	°C	1100	1300	1370	1500	1260	1300	1500	1550	1650	1550	1550	1650	1550	1600	1550	1550
Approximate Weight Required for Casting, Gunning	kg/cm <sup>3</sup>	1000	1420	1300	2660	2000	2000	2000	2100	2668	2100	2120	2250	2300	2350	2450	2600
Bulk Density, After Drying at 110°C	kg/cm <sup>3</sup>	1200	1400	1410	2350	2160	2110	2120	2160	2470	2160	2275	2350	2400	2500	2500	2650
Modulus of Rupture, After Drying at 110°C	kg/cm <sup>2</sup>	20	50	40	110	50	90	80	80	120	80	120	110	90	100	120	90
Cold Crushing Strength, After Drying at 110°C	kg/cm <sup>2</sup>	90	125	180	320	350	400	360	500	650	500	700	680	500	540	500	400
Permanent Linear Change	%	-1.00	-0.60	-1.30	+1.00	+0.60	-0.45	+0.90	+0.8	-1.00	+0.8	+0.8	+1.6	+0.8	-0.6	+0.5	-0.6
After Heating at	°C	1040	1300	1370	1500	1260	1300	1500	1550	1650	1550	1550	1650	1550	1600	1500	1500
<b>Thermal Conductivity</b>																	
at 400 °C	(W/m.K)	0.3	0.6	0.4	3	1.1	1.2	1.3	1.2	2.1	1.2	1.2	2.1	1.3	1.3	2.2	3.7
at 600 °C	(W/m.K)	0.3	0.6	0.5	2.6	1.1	1.2	1.3	1.2	2.1	1.2	1.2	2.1	1.3	1.3	2.2	3.5
at 1000 °C	(W/m.K)	0.4	0.6	0.5	2.2	1.1	1.2	1.3	1.2	2.1	1.2	1.2	2.1	1.3	1.3	2.2	3.1
<b>Chemical Composition:</b>																	
Alumina (Al <sub>2</sub> O <sub>3</sub> )	%	14.0	47.0	56.0	40.0	36.0	44.0	55.0	55.0	68.0	55.0	48.0	65.0	47.0	55.0	60.0	44.0
Silica (SiO <sub>2</sub> )	%	52.0	34.0	24.0	11.0	50.0	42.0	35.0	37.0	27.0	37.0	45.0	28.0	39.0	36.0	32.0	30.0
Iron Oxide (Fe <sub>2</sub> O <sub>3</sub> )	%	0.5	1.5	1.5	-	1.5	1.0	1.0	0.9	0.9	0.9	1.0	1.2	-	-	1.0	0.7
Silicon Carbide (SiC)	%	-	-	-	40.0	-	-	-	-	-	-	-	-	10	5.0	-	-
Lime (CaO)	%	29.0	15.0	15.0	7.0	9.5	9.5	7.0	2.4	2.4	2.4	2.4	2.5	2.4	2.5	2.0	1.5